

(19) World Intellectual Property Organization
International Bureau



(43) International Publication Date
10 August 2006 (10.08.2006)

PCT

(10) International Publication Number
WO 2006/083889 A1

- (51) International Patent Classification:
A61B 17/00 (2006.01) A61B 17/08 (2006.01)
- (21) International Application Number:
PCT/US2006/003432
- (22) International Filing Date: 31 January 2006 (31.01.2006)
- (25) Filing Language: English
- (26) Publication Language: English
- (30) Priority Data:
11/048,503 1 February 2005 (01.02.2005) US
- (71) Applicant (for all designated States except US): **ABBOTT LABORATORIES** [US/US]; 100 Abbott Park, Abbott Park, Illinois 60064 (US).
- (72) Inventors; and
- (75) Inventors/Applicants (for US only): **JABBA, Ronald** [US/US]; 144 Oakdale Street, Redwood City, California 94062 (US). **BELEF, W., Martin** [US/US]; 1177 Britton Avenue, San Jose, California 95125 (US).
- (74) Agents: **ROY, Fraser, D.** et al.; Workman Nydegger, 1000 Eagle Gate Tower, 60 East South Temple, Salt Lake City, Utah 84111 (US).
- (81) Designated States (unless otherwise indicated, for every kind of national protection available): AE, AG, AL, AM,

AT, AU, AZ, BA, BB, BG, BR, BW, BY, BZ, CA, CH, CN, CO, CR, CU, CZ, DE, DK, DM, DZ, EC, EE, EG, ES, FI, GB, GD, GE, GH, GM, HR, HU, ID, IL, IN, IS, JP, KE, KG, KM, KN, KP, KR, KZ, LC, LK, LR, LS, LT, LU, LV, LY, MA, MD, MG, MK, MN, MW, MX, MZ, NA, NG, NI, NO, NZ, OM, PG, PH, PL, PT, RO, RU, SC, SD, SE, SG, SK, SL, SM, SY, TJ, TM, TN, TR, TT, TZ, UA, UG, US, UZ, VC, VN, YU, ZA, ZM, ZW.

(84) Designated States (unless otherwise indicated, for every kind of regional protection available): ARIPO (BW, GH, GM, KE, LS, MW, MZ, NA, SD, SL, SZ, TZ, UG, ZM, ZW), Eurasian (AM, AZ, BY, KG, KZ, MD, RU, TJ, TM), European (AT, BE, BG, CH, CY, CZ, DE, DK, EE, ES, FI, FR, GB, GR, HU, IE, IS, IT, LT, LU, LV, MC, NL, PL, PT, RO, SE, SI, SK, TR), OAPI (BF, BJ, CF, CG, CI, CM, GA, GN, GQ, GW, ML, MR, NE, SN, TD, TG).

Published:
— with international search report
— before the expiration of the time limit for amending the claims and to be republished in the event of receipt of amendments

For two-letter codes and other abbreviations, refer to the "Guidance Notes on Codes and Abbreviations" appearing at the beginning of each regular issue of the PCT Gazette.

(54) Title: CLIP APPLIER AND METHODS OF USE

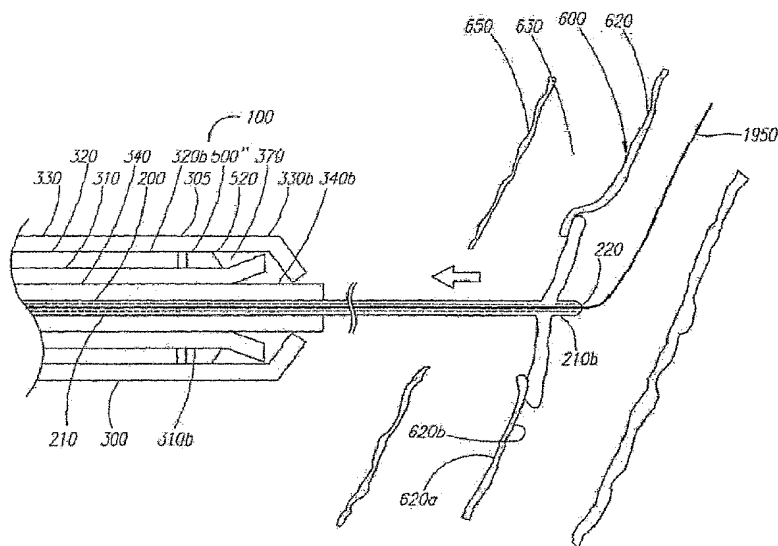

(57) Abstract: An apparatus for delivering a closure element into an opening formed in a blood vessel or other body lumen and methods for manufacturing and using same. The apparatus is configured to retain the closure element such that the closure element is disposed substantially within the apparatus. The apparatus also can engage, and position the closure element substantially adjacent to, the blood vessel wall adjacent to the opening. During deployment of the closure element, the apparatus expands the closure element beyond a natural cross-section of the closure element such that the closure element, when deployed, is configured to engage a significant amount of the blood vessel wall and/or tissue. Engaging the blood vessel wall and/or tissue, the closure element is further configured to return to the natural cross-section, thereby drawing the engaged blood vessel wall and/or tissue substantially closed and/or sealed, such that hemostasis within the opening is enhanced.



WO 2006/083889 A1

CLIP APPLIER AND METHODS OF USE
FIELD OF THE INVENTION

The present invention relates generally to apparatus and methods for closing and/or sealing openings through tissue, and more particularly to apparatus and methods for delivering a closure element for closing a puncture in a blood vessel or
5 other body lumen formed during a diagnostic or therapeutic procedure.

BACKGROUND OF THE INVENTION

Catheterization and interventional procedures, such as angioplasty or stenting, generally are performed by inserting a hollow needle through a patient's skin
10 and tissue into the vascular system. A guide wire may be advanced through the needle and into the patient's blood vessel accessed by the needle. The needle is then removed, enabling an introducer sheath to be advanced over the guide wire into the vessel, e.g., in conjunction with or subsequent to a dilator. A catheter or other device may then be advanced through a lumen of the introducer sheath and over the guide
15 wire into a position for performing a medical procedure. Thus, the introducer sheath may facilitate introducing various devices into the vessel, while minimizing trauma to the vessel wall and/or minimizing blood loss during a procedure.

Upon completing the procedure, the devices and introducer sheath would be removed, leaving a puncture site in the vessel wall. Traditionally external pressure
20 would be applied to the puncture site until clotting and wound sealing occur, however, the patient must remain bedridden for a substantial period of time after clotting to ensure closure of the wound. This procedure, however, may be time consuming and expensive, requiring as much as an hour of a physician's or nurse's time. It is also uncomfortable for the patient, and requires that the patient remain immobilized in the
25 operating room, catheter lab, or holding area. In addition, a risk of hematoma exists from bleeding before hemostasis occurs.

Various apparatus have been suggested for percutaneously sealing a vascular puncture by occluding the puncture site. For example, U.S. Patent Nos. 5,192,302 and 5,222,974, issued to Kensey et al., describe the use of a biodegradable
30 plug that may be delivered through an introducer sheath into a puncture site. Another technique has been suggested that involves percutaneously suturing the puncture site, such as that disclosed in U.S. Patent No. 5,304,184, issued to Hathaway et al.

To facilitate positioning devices that are percutaneously inserted into a blood vessel, “bleed back” indicators have been suggested. For example, U.S. Patent No. 5,676,974, issued to Kensey et al., discloses a bleed back lumen intended to facilitate positioning of a biodegradable plug within a puncture site. This device, however, requires that an anchor of the plug be positioned within the vessel, and therefore, may increase the risk of over-advancement of the plug itself into the vessel.

Alternatively, U.S. Patent No. 5,674,231, issued to Green et al., discloses a deployable loop that may be advanced through a sheath into a vessel. The loop is intended to resiliently expand to engage the inner wall of the vessel, thereby facilitating holding the sheath in a desired location with respect to the vessel.

Accordingly, apparatus and methods for delivering a device for closing a vascular puncture site or other opening through tissue would be useful.

SUMMARY OF THE INVENTION

The present invention is directed toward an apparatus and method for delivering a closure element through tissue and into an opening formed in, or adjacent to, a wall of a blood vessel or other body lumen of any size.

The apparatus is configured to receive and retain the closure element such that the closure element is disposed substantially within the apparatus. Thereby, if the apparatus is introduced via an introducer sheath, for example, the closure element can be disposed within, and delivered by way of, a lumen of the introducer sheath. The apparatus also is configured to engage the blood vessel wall adjacent to the opening and to position the closure element substantially adjacent to an outer surface of the blood vessel wall adjacent to the opening.

When properly positioned, the apparatus can be activated to distally deploy the closure element. During deployment, the apparatus preferably is configured to substantially uniformly expand the closure element beyond a natural cross-section of the closure element such that the closure element, when deployed, is configured to engage significant amount of the blood vessel wall and/or tissue. Engaging the blood vessel wall and/or tissue, the closure element is further configured to return to the natural cross-section. Thereby, the engaged blood vessel wall and/or tissue are drawn substantially closed and/or sealed, such that, for example, hemostasis within the opening is enhanced.

Other aspects and features of the present invention will become apparent from consideration of the following description taken in conjunction with the accompanying drawings.

BRIEF DESCRIPTION OF THE DRAWINGS

5 Fig. 1 provides a general illustration of an apparatus for closing openings formed in blood vessel walls in accordance with the present invention.

Fig. 2A illustrates one embodiment of a locator assembly for the apparatus of Fig. 1.

10 Fig. 2B illustrates one embodiment of a distal end region of the locator assembly of Fig. 2A when the distal end region is in an unexpanded state.

Fig. 2C illustrates the distal end region of the locator assembly of Fig. 2B when the distal end region is in an expanded state.

Fig. 2D illustrates one embodiment of a proximal end region of the locator assembly of Fig. 2A.

15 Fig. 3A illustrates one embodiment of a carrier assembly for the apparatus of Fig. 1.

Fig. 3B illustrates one embodiment of a carrier member for the carrier assembly of Fig. 3A.

20 Fig. 3C illustrates one embodiment of a pusher member for the carrier assembly of Fig. 3A.

Fig. 3D illustrates one embodiment of a cover member for the carrier assembly of Fig. 3A.

Fig. 3E illustrates one embodiment of a support member for the carrier assembly of Fig. 3A.

25 Fig. 4A illustrates a cross-sectional side view of one embodiment of a triggering system for the carrier assembly of Fig. 3A.

Fig. 4B illustrates a first detailed cross-sectional side view of the triggering system of Fig. 4A.

Fig. 4C illustrates a detailed view of the triggering system of Fig. 4B.

30 Fig. 4D illustrates a second detailed cross-sectional side view of the triggering system of Fig. 4A.

Fig. 5A illustrates the carrier control system of Figs. 4A-D as the carrier assembly of Fig. 3A moves distally from an initial predetermined position.

Fig. 5B illustrates the carrier control system of Figs. 4A-D as the carrier assembly of Fig. 3A reaches a first predetermined position.

Fig. 5C illustrates the carrier control system of Figs. 4A-D as the carrier assembly of Fig. 3A reaches a second predetermined position.

5 Fig. 6A illustrates a top view of one embodiment of a closure element in a natural, planar configuration and with a natural cross-section for use with the apparatus of Fig. 1.

Fig. 6B illustrates a side view of the closure element of Fig. 6A.

10 Fig. 6C illustrates a top view of the closure element of Figs. 6A-B after a natural cross-section of the closure element has been reduced.

Fig. 6D illustrates a side view of the reduced closure element of Fig. 6C.

Fig. 6E illustrates a side view of the reduced closure element of Figs. 6C-D as the reduced closure element transitions from the natural, planar configuration to a tubular configuration.

15 Fig. 6F illustrates a bottom view of the closure element of Figs. 6C-D upon completing the transition from the natural, planar configuration to a substantially tubular configuration.

Fig. 6G illustrates a side view of the closure element of Fig. 6F.

20 Fig. 7A illustrates the closure element of Figs. 6A-G prior to being disposed upon the carrier member of Fig. 3B.

Fig. 7B illustrates the closure element of Figs. 6A-G upon being disposed upon the carrier member of Fig. 3B.

Fig. 7C illustrates the closure element of Figs. 6A-G as the cover member of Fig. 3D receives the carrier member of Fig. 3B.

25 Fig. 7D illustrates the closure element of Figs. 6A-G being retained substantially within the carrier assembly of Fig. 3A when the carrier member of Fig. 3B is disposed substantially within the cover member of Fig. 3D.

Fig. 8A illustrates a sheath that is positioned through tissue and into an opening formed in a wall of a blood vessel.

30 Fig. 8B illustrates the apparatus of Fig. 1 as prepared to be received by the sheath of Fig. 8A.

Fig. 8C illustrates a locator assembly of the apparatus of Fig. 8B being advanced distally into the blood vessel.

Fig. 8D illustrates a distal end region of the locator assembly of Fig. 8C extending into the blood vessel and being transitioned into an expanded state.

Fig. 8E illustrates the distal end region of Fig. 8D being retracted proximally to engage an inner surface of the blood vessel wall.

5 Fig. 8F illustrates a carrier assembly of the apparatus of Fig. 8B being advanced distally into the sheath of Fig. 8A once the distal end region of Fig. 8D has engaged the inner surface of the blood vessel wall.

Fig. 8G illustrates relative positions of a tube set of the carrier assembly of Fig. 8F upon reaching a first predetermined position.

10 Fig. 8H illustrates the relative positions of the tube set of Fig. 8G upon reaching a second predetermined position.

Fig. 8I illustrates a position of a pusher member of the tube set of Fig. 8H moving distally from the second predetermined position and beginning to distally deploy a closure element.

15 Fig. 8J illustrates the closure element of Fig. 8I upon being deployed and engaging tissue adjacent to the opening in the blood vessel wall.

Fig. 8K illustrates the closure element of Fig. 8J transitioning from the substantially tubular configuration to the natural, planar configuration while engaging the engaged tissue.

20 Fig. 8L illustrates the closure element of Fig. 8K drawing the engaged tissue substantially closed and/or sealed

Fig. 9 illustrates one embodiment of an introducer sheath for the apparatus of Fig. 1.

25 Fig. 10A illustrates an assembly view of the components included in an alternative embodiment of the apparatus for closing openings formed in blood vessel walls.

Fig. 10B illustrates an assembly view of the components shown in Fig. 10A, showing the reverse view of that shown in Fig. 10A.

30 Fig. 11A illustrates the assembled carrier assembly and triggering assembly of the alternative embodiment of the apparatus shown in Fig. 10A.

Fig. 11B illustrates a close-up view of the proximal end of the apparatus shown in Fig. 11A.

Fig. 12 illustrates the apparatus of Fig. 11A after advancement of the locator assembly block.

Fig. 13A illustrates the apparatus of Fig. 12 after distal advancement of the triggering system and carrier assembly. Fig. 13B illustrates a close-up view of the distal end of the housing and internal components of the apparatus shown in Fig. 13A.

Fig. 14A illustrates the apparatus of Fig. 13 after further distal advancement of the triggering system and carrier assembly.

Fig. 14B illustrates a close-up view of the distal end of the housing and internal components of the apparatus shown in Fig. 14A.

Fig. 15 illustrates a reverse view of the apparatus of Figs. 11-14, showing the locator release system.

Fig. 16 illustrates a side view of another alternative embodiment of an apparatus for closing openings formed in blood vessel walls.

Fig. 16A illustrates a close-up view of the distal end of the device shown in Fig. 16.

Fig. 17 illustrates a perspective view of the proximal end of the device shown in Fig. 16.

Fig. 17A illustrates a close-up view of the proximal end of the device shown in Fig. 17.

Fig. 18 illustrates a cross-sectional view of the device shown in Fig. 16.

Fig. 18A illustrates a close-up cross-sectional view of a portion of the device shown in Fig. 18.

Fig. 18B illustrates a close-up cross-sectional view of a portion of the device shown in Fig. 18.

Fig. 19 illustrates a close-up cross-sectional view of the proximal end of the device shown in Fig. 16.

Fig. 20A is a cross-sectional side view illustrating an opening formed in a vessel, wherein a guidewire is shown disposed within the opening.

Figs. 20B-20F are partial cross-sectional views illustrating the alternative embodiment of the closure device in accordance with the present invention wherein the device is illustrated being disposed over a guidewire.

Fig. 20G is a partial cross-sectional view illustrating the placement of a closure element in accordance with the device illustrated in Figs 20B-20F.

It should be noted that the figures are not drawn to scale and that elements of similar structures or functions are generally represented by like reference numerals for illustrative purposes throughout the figures. It also should be noted that the figures are only intended to facilitate the description of the preferred embodiments of the present invention. The figures do not describe every aspect of the present invention and do not limit the scope of the invention.

DETAILED DESCRIPTION OF THE PREFERRED EMBODIMENTS

Since current apparatuses for sealing openings formed in blood vessel walls can snag tissue adjacent to the openings during positioning and may not provide an adequate seal, an apparatus that is configured to prevent inadvertent tissue contact during positioning and to engage a substantial amount of tissue adjacent to the opening can prove much more desirable and provide a basis for a wide range of medical applications, such as diagnostic and/or therapeutic procedures involving blood vessels or other body lumens of any size. This result can be achieved, according to one embodiment of the present invention, by employing an apparatus 100 as shown in Fig. 1.

As will be discussed in more detail below, the apparatus 100 can deliver a closure element 500 (shown in Figs. 6A-B) through tissue 630 (shown in Fig. 8A) and into an opening 610 (shown in Fig. 8A) formed in and/or adjacent to a wall 620 (shown in Fig. 8A) of a blood vessel 600 (shown in Fig. 8A) or other body lumen. The closure element (or clip) 500 preferably has a generally annular-shape body 510 (shown in Figs. 6A-B) defining a channel 540 and one or more barbs and/or tines 520 (shown in Figs. 6A-B) for receiving and engaging the blood vessel wall 620 and/or the tissue 630 around the opening 610. Although the closure element 500 has a natural shape and size, the closure element 500 can be deformed into other shapes and sizes, as desired, and is configured to return to the natural shape and size when released. For example, the closure element 500 can have a natural, planar configuration with opposing tines 520 and a natural cross-section 530 as shown in Figs. 6A-B. The natural cross-section 530 of the closure element 500 can be reduced to form a reduced closure element 500' that has a natural, planar configuration with opposing tines 520 and a reduced cross-section 530' as shown in Figs. 6C-D. By rotating the opposing tines 520 axially as shown in Fig. 6E, the reduced closure element 500' can be further deformed to form a substantially tubular closure element

500" (shown in Fig. 6F) having the reduced cross-section 530' as well as being in a substantially tubular configuration with the tines 520 in an axial configuration.

Being configured to draw the blood vessel wall 620 and/or the tissue 630 adjacent to the opening 610 substantially closed and/or to enhance hemostasis within the opening 610, the closure element 500 can be formed from any suitable material, including any biodegradable material, any shape memory alloy, such as alloys of nickel-titanium, or any combination thereof. Additionally, it is contemplated that the closure element may be coated with a beneficial agent or be constructed as a composite, wherein one component of the composite would be a beneficial agent. As desired, the closure element 500 may further include radiopaque markers (not shown) or may be wholly or partially formed from a radiopaque material to facilitate observation of the closure element 500 using fluoroscopy or other imaging systems. Exemplary embodiments of a closure element are disclosed in U.S. Patents Nos. 6,197,042, and 6,623,510, and in co-pending applications Serial Nos. 09/546,998, 09/610,238, and 10/081,726. The disclosures of these references and any others cited therein are expressly incorporated herein by reference.

The apparatus 100 is configured to receive and retain the closure element 500 such that the closure element 500 is disposed substantially within the apparatus 100. Thereby, if the apparatus 100 is introduced via an introducer sheath 640 (shown in Fig. 8A), for example, the closure element 500 can be disposed within, and delivered by way of, a lumen 644 (shown in Fig. 8A) of the introducer sheath 640. The apparatus 100 also is configured to engage the blood vessel wall 620 adjacent to the opening 610. Being disposed substantially within the apparatus 100, the closure element 500 can deeply penetrate, without inadvertently contacting, tissue 630 adjacent to the opening 610 such that the apparatus 100 can position the closure element 500 substantially adjacent to an outer surface 620a (shown in Fig. 8A) of the blood vessel wall 620 adjacent to the opening 610.

When properly positioned, the apparatus 100 can be activated to deploy the closure element 500. Although preferably configured to substantially uniformly expand the closure element 500 beyond the natural cross-section 530 of the closure element 500 during deployment, the apparatus 100, as desired, can deploy the closure element 500 without expanding the closure element 500. The closure element 500, when deployed, is configured to engage a significant amount of the blood vessel wall

620 and/or tissue 630 adjacent to the opening 610. Engaging the blood vessel wall 620 and/or tissue 630, the closure element 500 is further configured to return to the natural cross-section 530. Thus, the engaged blood vessel wall 620 and/or tissue 630 are drawn substantially closed and/or sealed, such that, for example, hemostasis
5 within the opening 610 is enhanced.

The apparatus 100 can be provided as one or more integrated components and/or discrete components. As shown in Fig. 1, for example, the apparatus 100 can comprise a locator (or obturator) assembly 200 and a carrier assembly 300. For purposes of illustration, the locator assembly 200 and the carrier assembly 300 are
10 shown in Fig. 1 as comprising substantially separate assemblies. As desired, however, the locator assembly 200 and the carrier assembly 300 each can be provided, in whole or in part, as one or more integrated assemblies.

Being configured to extend into the opening 610, the locator assembly 200 can selectably contact the inner surface 620b of the blood vessel wall 620 adjacent the opening 610. Whereby, the locator assembly 200 is configured to draw the blood
15 vessel wall 620 taut and maintain the proper position of the apparatus 100 in relation to the opening 610 as the blood vessel 600 pulsates. The locator assembly 200 can be provided in the manner disclosed in co-pending applications Serial Nos. 09/732,835 and 10/081,723, the disclosures of which are expressly incorporated herein by
20 reference. The locator assembly 200 preferably includes a flexible or semi-rigid tubular body 210. As illustrated in Fig. 2A, the tubular body 210 has a proximal end region 210a and a distal end region 210b and includes a predetermined length 218a and a predetermined outer cross-section 218b, both of which can be of any suitable dimension. The distal end region 210b of the locator assembly 200 preferably
25 includes a substantially rounded, soft, and/or flexible distal end or tip 220 to facilitate atraumatic advancement and/or retraction of the distal end region 210b into the blood vessel 600. As desired, a pigtail (not shown) may be provided on the distal end 220 to further aid atraumatic advancement of the distal end region 210b.

The distal end region 210b of the locator assembly 200 further is
30 selectably controllable between an unexpanded state and an expanded state. In the unexpanded state, the distal end region 210b has an unexpanded size; whereas, the distal end region 210b in the expanded state has an expanded size, which is greater than the unexpanded size of the distal end region 210b in the unexpanded state. The

distal end region 210b is configured to expand from the unexpanded size to the expanded size and/or to contract from the expanded size to the unexpanded size, and the expansion and contraction of the distal end region 210b preferably is substantially uniform about a longitudinal axis of the locator assembly 200. For example, one or
5 more expansion elements 230 can be provided on the distal end region 210b and can be configured to expand substantially transversely with respect to a longitudinal axis of the locator assembly 200. Preferably being substantially equally distributed about an outer periphery 212 of the distal end region 210b, the expansion elements 230 may include radiopaque markers (not shown) or may be wholly or partially formed from a
10 radiopaque material to facilitate observation of the expansion elements 230 and/or the distal end region 210b using fluoroscopy or other imaging systems.

At least one, and preferably all of the expansion elements 230 can comprise a substantially flexible member 230' with a substantially fixed end region 230a', an intermediate region 230b', and a movable end region 230c' as shown in
15 Figs. 2B-C. For each substantially flexible member 230', the fixed end region 230a' is fixedly coupled with the distal end region 210b; whereas, the movable end region 230c' is movably coupled with the distal end region 210b and configured to be axially movable relative to the fixed end region 230a'. When each movable end region 230c' is axially moved toward the relevant fixed end region 230a', the intermediate regions
20 230b' buckle and/or expand transversely outwardly, thereby transitioning the distal end region 210b of the locator assembly 200 from the unexpanded state to the expanded state. In contrast, the distal end region 210b transitions from the expanded state to the unexpanded state as each of the movable end regions 230c' are axially moved away from the relevant fixed end region 230a'. Although the expansion
25 elements 230 are shown as comprising the flexible members 230' in Figs. 2B-C for purposes of illustration, it is understood that the expansion elements 230 can comprise any type of expansion elements and are not limited to the illustrated embodiments. It is further contemplated that the expansion elements 230 may further include geometric features that allow/enhance the ability of the expansion elements to bend or
30 fold from a retracted position to an expanded position. The expansion elements may be constructed of a material such as steel, spring steel, plastics or composites. In a preferred embodiment, the expansion elements are constructed of nitinol.

Referring now to Fig 2D, the locator assembly 200 may further include a locator control system associated with the locator assembly. As shown in Fig. 2D, the locator control system 240 is associated with the proximal end region 210a of the locator assembly 200 and is configured to selectively control the distal end region 210b of the locator assembly 200 between the unexpanded and expanded states. The locator control system 240 can selectively control the distal end region 210b between the unexpanded and expanded states, such as by being activated by a switching system (not shown). For example, a control member 250, such as a rod, wire, or other elongate member, can be moveably disposed within a lumen (not shown) formed by the tubular body 210 and extending substantially between the proximal end region 210a and the distal end region 210b. The control member 250 has a proximal end region 250a that is coupled with the locator control system 240, preferably via a control block 260 (shown in Fig. 4D), and a distal end region (not shown) that is coupled with the distal end region 210b of the locator assembly 200, the expansion elements 230, and/or the movable end regions 230c' of the substantially flexible members 230'. The locator control system 240 can selectively transition the distal end region 210b, the expansion elements 230, and/or the substantially flexible members 230' between the unexpanded and expanded states by moving the control member 250 axially relative to the tubular body 210.

The locator control system 240 further includes a locator release system 490 for maintaining the unexpanded state and/or the expanded state of the distal end region 210b, the expansion elements 230, and/or the substantially flexible members 230'. Preferably being configured to maintain the expanded state of the distal end region 210b, the locator release system 490 can comprise any type of locking system and can be engaged, for instance, by activating the switching system. For example, once the substantially flexible members 230' have entered the expanded state, the locator release system 490 can secure the control member 250 to prevent axial movement relative to the tubular body 210, thereby maintaining the substantially flexible members 230' in the expanded state.

In the manner described in more detail below, the locator control system 240 also can be configured to disengage the locator release system 490, such that the distal end region 210b, the expansion elements 230, and/or the substantially flexible members 230' can transition between the expanded and unexpanded states. The

locator release system 490 can be disengaged, for example, by activating an emergency release system (not shown). As desired, the locator control system 240 may further include a biasing system (not shown), such as one or more springs or other resilient members, to bias the distal end region 210b, the expansion elements 5 230, and/or the substantially flexible members 230' to enter and/or maintain the unexpanded state when the locator release system 490 is disengaged.

Returning to Fig. 1, the carrier assembly 300 is coupled with, and slidable relative to, the locator assembly 200. The carrier assembly 300 is configured to receive and retain the closure element 500 (shown in Figs. 6A-B), which preferably is 10 disposed substantially within the carrier assembly 300. When the locator assembly 200 engages the inner surface 620b (shown in Fig. 8A) of the blood vessel wall 620 (shown in Fig. 8A), the carrier assembly 300 is further configured to position the closure element 500 substantially adjacent to the opening 610 (shown in Fig. 8A) and to deploy the closure element 500. Upon being deployed, the closure element 500 can 15 maintain the reduced cross-section 530' (shown in Figs. 6C-D) but preferably can temporarily and substantially uniformly expand beyond the natural cross-section 530 (shown in Figs. 6A-B) of the closure element 500. In either case, the closure element 500, when deployed, can engage a significant amount of the blood vessel wall 620 and/or tissue 630 adjacent to the opening 610. Thereafter, the closure element 500 is 20 configured to return to the natural cross-section 530, preferably substantially uniformly, such that the blood vessel wall 620 and/or tissue 630 is drawn substantially closed and/or sealed.

Turning to Figs. 3A-D, the carrier assembly 300 can include a tube set 305, comprising a carrier member 310, a pusher member 320, a support tube 340, and 25 a cover member 330. The carrier member 310, the pusher member 320, the support tube 340, and the cover member 330 can be provided as a plurality of nested, telescoping members with a common longitudinal axis 350 as illustrated in Fig. 3A. The carrier member 310 is configured to receive and support the closure element 500. While being disposed on the carrier member 310, the closure element 500 preferably 30 is deformed from the natural, planar configuration to form the substantially tubular closure element 500'' (shown in Figs. 6F-G) as will be discussed in more detail below. Being disposed substantially about, and supported by, an outer periphery 312b of the carrier member 310, the substantially tubular closure element 500'' can be

substantially in axial alignment with the carrier member 310 with the tines 520 pointed substantially distally.

Preferably being formed as a substantially rigid, semi-rigid, or flexible tubular member, the carrier member 310 has a proximal end region 310a and a distal end region 310b and includes a predetermined length 318a and a predetermined cross-section 318b, both of which can be of any suitable dimension. The carrier member 310 also can define a lumen 314 that extends substantially between the proximal end region 310a and the distal end region 310b and that is configured to slidably receive at least a portion of the tubular body 210 of the locator assembly 200. Although the cross-section 318b of the carrier member 310 generally is substantially uniform, the distal end region 310b of the carrier member 310 preferably has a cross-section that increases distally, as illustrated in Figs. 3A-B, for substantially uniformly expanding the substantially tubular closure element 500" beyond the natural cross-section 530 of the closure element 500 when the substantially tubular closure element 500" is deployed. To deploy the closure element 500 without expanding the closure element 500, the distal end region 310b can be formed with a cross-section (not shown) that is substantially uniform. Although shown and described as having the cross-section that increases distally for expanding the substantially tubular closure element 500", it will be understood that the distal end region 310b of the carrier member 310 can be provided with the substantially-uniform cross-section and that the substantially tubular closure element 500" can be deployed without being expanded.

Being configured to distally deploy the substantially tubular closure element 500", the pusher member 320 has a proximal end region 320a and a distal end region 320b and is coupled with, and slidable relative to, the carrier member 310. The pusher member 320 includes a predetermined length 328a and a predetermined cross-section 328b, both of which can be of any suitable dimension and can be configured to slidably receive the carrier member 310 such that the distal end region 320b of the pusher member 320 is offset proximally from the distal end region 310b of the carrier member 310. As desired, the predetermined length 328a of the pusher member 320 can be greater than or substantially equal to the predetermined length 318a of the carrier member 310. The predetermined length 328a of the pusher member 320 however is preferably less than the predetermined length 318a of the carrier member 310 such that the carrier member 310 and the pusher member 320 at least partially

define a space 360 distal to the distal end region 320b of the pusher member 320 and along the periphery 312b of the carrier member 310.

Being formed from a substantially rigid, semi-rigid, or flexible material, the pusher member 320 preferably is substantially tubular and can define a lumen 324
5 that extends substantially between the proximal end region 320a and the distal end region 320b and that is configured to slidably receive at least a portion of the carrier member 310. The cross-section 328b of the pusher member 320 preferably is substantially uniform, and the distal end region 320b of the pusher member 320 can
10 comprise one or more longitudinal extensions 325, which extend distally from the pusher member 320 and along the periphery 312b of the carrier member 310 as shown in Fig. 3C. The longitudinal extensions 325 preferably are biased such that the longitudinal extensions 325 extend generally in parallel with common longitudinal axis 350. The longitudinal extensions 325 are sufficiently flexible to expand radially, and yet sufficiently rigid to inhibit buckling, as the distal end region 320b is directed
15 distally along the carrier member 310 and engage the distally-increasing cross-section of the distal end region 310b of the carrier member 310 to deploy the substantially tubular closure element 500”.

A cover member 330 is configured to retain the substantially tubular closure element 500” substantially within the carrier assembly 300 prior to
20 deployment as shown in Fig. 3D. Being coupled with, and slidable relative to, the pusher member 320, the cover member 330 has a proximal end region 330a and a distal end region 330b and includes a predetermined length 338a and a predetermined cross-section 338b, both of which can be of any suitable dimension. Preferably being formed as a substantially rigid, semi-rigid, or flexible tubular member, the cover
25 member 330 has an inner periphery 332a and an outer periphery 332b and can define a lumen 334. The lumen 334 extends substantially between the proximal and distal end regions 330a, 330b of the cover member 330 and can be configured to slidably receive at least a portion of the pusher member 320. When the cover member 330 is properly positioned within the carrier assembly 300, the distal end region 330b is
30 configured to extend over the space 360, thereby defining an annular cavity 370 for receiving and retaining the substantially tubular closure element 500”.

The cross-section 338b of the cover member 330 preferably is substantially uniform, and the distal end region 330b of the cover member 330

preferably comprises one or more longitudinal extensions 335, which extends distally from the cover member 330 and along an outer periphery 322b of the pusher member 320 as shown in Fig. 3D. Although the longitudinal extensions 335 can extend generally in parallel with common longitudinal axis 350, the longitudinal extensions 335 preferably are biased such that the plurality of longitudinal extensions 335 extend substantially radially inwardly as illustrated in Figs. 3A and 3D. Thereby, the longitudinal extensions 335 can at least partially close the lumen 334 substantially adjacent to the distal end region 330b of the cover member 330. To permit the substantially tubular closure element 500" to be deployed from the annular cavity 370, the longitudinal extensions 335 preferably are sufficiently flexible to expand radially to permit the distal end region 310b of the carrier member 310 to move distally past the cover member 330 to open the annular cavity 370 such that the distal end region 330b no longer extends over the space 360.

If the carrier assembly 300 is assembled as the plurality of nested, telescoping members as shown in Fig. 3A, the carrier member 310 is at least partially disposed within, and slidable relative to, the lumen 324 of the pusher member 320 as shown in Fig. 3C. The pusher member 320, in turn, is at least partially disposed within, and slidable relative to, the lumen 334 of the cover member 330. To couple the carrier assembly 300 with the locator assembly 200, the tubular body 210 of the locator assembly 200 is at least partially disposed within, and slidable relative to, the lumen 314 of the carrier member 310. The longitudinal axis of the locator assembly 200 is preferably substantially in axial alignment with the common longitudinal axis 350 of the carrier member 310, the pusher member 320, the cover member 330, and the support tube 340.

It will be appreciated that the tube set 305 preferably also includes a support member 340 as shown in Figs. 3A and 3E. The support member 340 is configured to slidably receive the tubular body 210 of the locator assembly 200 and to provide radial support for the distal end region 210b of the tubular body 210 when the locator assembly 200 is coupled with the carrier assembly 300. The carrier assembly 300 can advantageously include the support member 340, for example, if the tubular body 210 is not sufficiently rigid or under other circumstances in which support for the tubular body 210 might be desirable. It also will be appreciated that the support member 340 also can be configured to inhibit the plurality of longitudinal extensions

335, which extend from the distal end region 330b of the cover member 330, from expanding prematurely prior to the closure element 500 being deployed.

The support member 340 is preferably formed as a substantially rigid, semi-rigid, or flexible tubular member, having a proximal end region 340a and a distal end region 340b. Wherein an outer periphery 342b of the support member 340 can define a lumen 344 that extends substantially between the proximal end region 340a and the distal end region 340b, the lumen is configured to slidably receive and support at least a portion of the tubular body 210 of the locator assembly 200. The support member 340, in turn, can be at least partially slidably disposed within the lumen 314 of the carrier member 310 such that the tubular body 210 of the locator assembly 200 may be coupled with, and slidable relative to, the carrier member 310 in the manner described in more detail above. The support member 340 has a predetermined length 348a and a predetermined cross-section 348b, both of which can be of any suitable dimension, and the cross-section 348b preferably is substantially uniform. Although shown and described as being substantially separate for purposes of illustration, it will be appreciated that the carrier member 310, the pusher member 320, the cover member 330, and/or the support member 340 can be provided, in whole or in part, as one or more integrated assemblies.

The carrier assembly 300 may further include a housing 380 as illustrated in Fig. 4A. Preferably being formed as an elongate member with a longitudinal axis 386, the housing 380 has an outer periphery 382b and includes a proximal end region 380a and a distal end region 380b. Thereby, when the apparatus 100 is properly assembled, the tubular body 210 of the locator assembly 200 at least partially disposed within the tube set 305 such that the distal end region 210b of the tubular body 210 extends beyond the distal end regions 310b, 320b, 330b, and/or 340b. The tubular body 210, the carrier member 310, the pusher member 320, the cover member 330, and, if provided, the support member 340 is at least partially disposed within, and slidable relative to, the housing 380, and the respective distal end regions 210b, 310b, 320b, 330b, and 340b extend from the distal end region 380b of the housing 380 such that the common longitudinal axis 350 (shown in Fig. 3A) of the tube set 305 is substantially axially aligned with the longitudinal axis 386 of the housing 380. Being configured to slidably retain the respective proximal end regions 210a, 310a, 320a, 330a, and 340a, the housing 380 supports the tube set 305 and can have one or

more handles 390 to facilitate use of the apparatus 100. The handles 390 extend substantially radially from the outer periphery 382b of the housing 380 and can be provided in the manner known in the art.

When the apparatus 100 is properly assembled, the tubular body 210 of the locator assembly 200 is at least partially disposed within the tube set 305 of the carrier assembly 300 such that the distal end region 210b of the tubular body 210 extends beyond the distal end regions 310b, 320b, 330b, and/or 340b. Further, the proximal end region 210a of the tubular body 210 and the proximal end regions 310a, 320a, 330a, and/or 340a of the tube set 305 are at least partially disposed within, and slidable relative to, the housing 380. The switching system of the locator assembly 200 and a switching system 450 of the triggering system 400 preferably are accessible external to the housing 380 as shown in Fig. 4A and 4C.

Turning to Figs. 4B-D, a triggering system 400 can be disposed substantially within the housing 380. The triggering system 400 is configured to control the relative axial movement and/or positioning of the respective distal end regions 310b, 320b, 330b, and 340b of the tube set 305 and/or the distal end region 210b of the locator assembly 200. Being coupled with the proximal end regions 210a, 310a, 320a, 330a, and/or 340a, the triggering system 400 can control the relative axial movement of the distal end regions 210b, 310b, 320b, 330b, and/or 340b in any manner, such as by being activated by the switching system 450. As desired, the triggering system 400 can induce axial motion, such as distal motion, with respect to one or more of the distal end regions 210b, 310b, 320b, 330b, and/or 340b. One or more of the distal end regions 210b, 310b, 320b, 330b, and/or 340b can be axially moved. Axial motion of one or more of the carrier member 310, the pusher member 320, the cover member 330, and the support member 340 and/or the tubular body 210 can be attained, for example, by applying an axial force to the switching system 450. To facilitate monitoring of the positioning of the carrier assembly 300 and/or the substantially tubular closure element 500", one or more of the distal end regions 210b, 310b, 320b, 330b, and/or 340b may include radiopaque markers (not shown) or may be wholly or partially formed from a radiopaque material.

The triggering system 400 is configured to overcome internal resistance such that the relative axial movement and/or positioning of the respective distal end regions 310b, 320b, 330b, and 340b of the tube set 305 and/or the distal end region

210b of the locator assembly 200 are controlled in accordance with a predetermined manner when the triggering system 400 is activated. Thereby, movement and/or positioning of the distal end regions 310b, 320b, 330b, 340b, and/or 210b is initiated when at least a predetermined quantity of force is applied to the switching system 5 450. Stated somewhat differently, a force that is less than the predetermined quantity generally is insufficient to activate the triggering system 400; whereas, when the force increases to a level that is greater than or substantially equal to the predetermined quantity, the triggering system 400 is configured to activate, move and/or position the distal end regions 310b, 320b, 330b, 340b, and/or 210b in accordance with the 10 predetermined manner. The triggering system 400, once activated, preferably continues to move and/or position the distal end regions 310b, 320b, 330b, 340b, and/or 210b in accordance with the predetermined manner until the closure element 500 is deployed.

The triggering system 400, for example, can comprise one or more sets of 15 cooperating detents for coupling the axial motion of the distal end regions 310b, 320b, 330b, and 340b in accordance with a predetermined manner when the triggering system 400 is activated. The term "detents" refers to any combination of mating elements, such as blocks, tabs, pockets, slots, ramps, locking pins, cantilevered members, support pins, and the like, that may be selectively or automatically engaged 20 and/or disengaged to couple or decouple the carrier member 310, the pusher member 320, the cover member 330, and the support member 340 relative to one another. It will be appreciated that the cooperating detents as illustrated and described below are merely exemplary and not exhaustive. For example, the cooperating detents can include a first set of cooperating blocks and pockets for releasably coupling the 25 support member 340, the carrier member 310, the pusher member 320, and the cover member 330. When the carrier assembly 300 reaches a first predetermined distal position, the support member 340 can be decoupled from the carrier member 310, the pusher member 320, and the cover member 330 and preferably is substantially inhibited from further axial movement. Thereby, the carrier member 310, the pusher member 320, and the cover member 330 may continue to be directed distally as the 30 support member 340 remains substantially stationary.

As shown in Figs. 4B-C, the cooperating detents can comprise a carrier block 410, a pusher block 420, a cover block 430, and a support block 440, which can

be configured to couple and decouple in accordance with the predetermined manner. For example, the carrier block 410 is disposed on the proximal end region 310a of the carrier member 310 and includes a carrier pin 412c that extends from the carrier block 410; whereas, the proximal end region 330a of the cover member 330 and the proximal end region 340a the support member 340 are respectively coupled with the cover block 430 and the support block 440. A cover pin 432b extends from the cover block 430, and the support block 440 has a support pin 442a, which extends from the support block 440. The support pin 442a, the cover pin 432b, and the carrier pin 412c each preferably are formed from a substantially rigid material, such as an alloy of nickel-titanium.

The pusher block 420 is disposed on the proximal end region 320a of the pusher member 320 and forms a support slot 422a, a cover slot 422b, and a carrier slot 422c. The support slot 422a is configured to receive and releasably engage the support pin 442a by which the support member 340 can be coupled with, and decoupled from, the pusher member 320. The cover member 330 can be coupled with, and decoupled from, the pusher member 320 via the cover slot 422b, which is configured to receive and releasably engage the cover pin 432b. The carrier slot 422c is configured to receive and releasably engage the carrier pin 412c such that the carrier member 310 can be coupled with, and decoupled from, the pusher member 320. The carrier block 410, the pusher block 420, the cover block 430, and the support block 440 preferably are respectively disposed substantially on the outer peripheries 312b, 322b, 332b, and 342b and can be configured to couple and decouple in accordance with the predetermined manner.

The triggering system 400 further includes one or more stops for engaging the pusher block 420, the cover block 430, and/or the support block 440, respectively. As illustrated in Fig. 4B, a support stop 460a, a cover stop 460b, and a carrier stop 460c each are formed in the housing 380 and are configured to receive, and substantially inhibit further movement of, the support block 440, the cover block 430, and the carrier block 410, respectively, in accordance with the predetermined manner. For example, when an axial force is applied to the tube set 305 via the switching system 450, the cover block 430 moves distally within the housing 380, and the cover block 430 approaches the cover stop 460b. Upon being received by the cover stop

460b, the cover block 430 is substantially locked in place, substantially preventing any further motion of the cover block 430.

Resisting the axial force, the cover pin 432b provides a static load while the axial force is less than the predetermined quantity of force. As the axial force increases to a level that is greater than or substantially equal to the predetermined quantity, the cover pin 432b is displaced from the cover slot 422b, decoupling the cover member 330 from the carrier member 310, the pusher member 320, and the support member 340. Creating the internal resistance to be overcome by the triggering system 400, the static forces provided by the pins 442a, 432b, and 412c is approximately proportional to a composition and cross-section of the respective pins 442a, 432b, and 412c and/or a depth and a slope of the respective slots 422a, 422b, and 422c. As desired, the pins 442a, 432b, and 412c can be configured to provide static loads that are differing and/or substantially uniform.

Turning to Fig. 4D, the triggering system 400 may further include a tube release system 470 for inhibiting inadvertent advancement of the tube set 305. The tube release system 470 is coupled with a tube release member 480, such as a rod, wire, or other elongate member. The tube release member 480 has a proximal end region 480a that is disposed substantially between the pusher block 420 and the housing 380 (shown in Fig. 4A) and a distal end region 480b that is coupled with the tube release system 470. Preferably, a tab 485 is coupled with the proximal end region 480a of the tube release member 480, and a pin (not shown) extends from the pusher block 420 and is disposed substantially between the tab 485 and a groove (not shown) formed in the housing 380. The tube release system 470 is configured to release the tube set 305 when the tube release member 480 is moved proximally, freeing the pusher block 420.

A locator release system 490 for permitting the distal end region 210b, the expansion elements 230, and/or the substantially flexible members 230' of the locator assembly 200 to transition from the expanded state to the unexpanded state can be included with the triggering system 400. The locator release system 490 can comprise a rod, wire, or other elongate member and has a proximal end region 490a and a distal end region 490b. The proximal end region 490a of the locator release system 490 can be coupled with, and configured to activate, the locator control system 240 (shown in Fig. 2D), and the distal end region 490b extends beyond the pusher block 420.

Thereby, when the pusher block 420 is advanced during deployment of the closure element 500, the control block 260 is disengaged such that the distal end region 210b, the expansion elements 230, and/or the substantially flexible members 230' of the locator assembly 200 to transition from the expanded state to the unexpanded state.

5 The operation of the triggering system 400 in accordance with one predetermined manner is illustrated in Figs. 5A-C with the closure element 500 (shown in Figs. 6A-B) disposed substantially within the apparatus 100. As shown in Fig. 5A, the distal end region 210b of the locator assembly 200 has been positioned as desired and has transitioned from the unexpanded state to the expanded state. While
10 the locator control system 240 (shown in Fig. 2D) maintains the distal end region 210b in the expanded state, a distally-directed axial force is applied to the triggering system 400 via the switching system 450. Once the tube release member 480 (shown in Fig. 4D) has been moved proximally to free the pusher block 420, the tube set 305 is substantially freely slidable within the housing 380 and responds to the axial force
15 by sliding distally from an initial predetermined position to a first predetermined position.

 In the initial predetermined position, the carrier member 310, the pusher member 320, the cover member 330, and the support member 340 are coupled via the slots 422c, 422b, and 422a (shown in Fig. 4C) and the pins 412c, 432b, and 442a
20 (shown in Fig. 4C). Stated somewhat differently, the support pin 442a, the cover pin 432b, and the carrier pin 412c are respectively disposed within, and engaged by, the support slot 422a, the cover slot 422b, and the carrier slot 422c such that the carrier block 410, the pusher block 420, the cover block 430, and the support block 440 are coupled as illustrated in Fig. 4C. Therefore, the carrier member 310, the pusher
25 member 320, the cover member 330, and the support member 340 each slide distally from the initial predetermined position to the first predetermined position in response to the axial force.

 Fig. 5B illustrates the positions of the carrier member 310, the pusher member 320, the cover member 330, and the support member 340 upon reaching the
30 first predetermined position. In the first predetermined position, the support block 440 and the cover block 430 respectively engage the support stop 460a and the cover stop 460b. Thereby, the support stop 460a receives, and substantially inhibits further movement of, the support block 440 and, therefore, the support member 340; whereas,

the cover stop 460b receives, and substantially inhibits further movement of, the cover block 430 and, therefore, the cover member 330. Although the support block 440 and the cover block 430 preferably engage the support stop 460a and the cover stop 460b in the first predetermined position, it will be appreciated that the support block 440
5 can engage the support stop 460a and the cover block 430 can engage the cover stop 460b in different predetermined positions. In other words, the predetermined manner can comprise any number of predetermined positions, each predetermined position being associated with any number of the blocks 410, 420, 430, and 440 engaging any number of relevant stops 460a, 460b, and 460c.

10 To continue distally from the first predetermined position, the carrier member 310 and the pusher member 320 can be decoupled from the cover member 330 and the support member 340 by disengaging the support pin 442a and the cover pin 432b from the support slot 422a and the cover slot 422b, respectively. In the manner described in more detail above with reference to Figs. 4B-C, the support pin
15 442a and the cover pin 432b each resist the axial force. While the axial force is less than the combined static force provided by the support pin 442a and the cover pin 432b, the carrier member 310 and the pusher member 320 remain coupled with the cover member 330 and the support member 340. As the axial force increases to a level that is greater than or substantially equal to the combined static force, the
20 support pin 442a and the cover pin 432b are respectively displaced from the support slot 422a and the cover slot 422b, decoupling the carrier member 310 and the pusher member 320 from the cover member 330 and the support member 340. Thereby, the cover member 330 and the support member 340 preferably are inhibited from further distal movement and remain substantially stationary; whereas, the carrier member 310
25 and the pusher member 320 proceed distally toward a second predetermined position.

The pusher member 320 and the carrier member 310 continue distally until the second predetermined position is reached as shown in Fig. 5C. In the second predetermined position, the carrier block 410 engages the carrier stop 460c. Whereby, the carrier stop 460c receives, and substantially inhibits further movement
30 of, the carrier block 410 and, therefore, the carrier member 310. To continue distally from the second predetermined position, the pusher member 320 can be decoupled from the carrier member 310 by disengaging the carrier pin 412c from the carrier slot 422c. In the manner described in more detail above with reference to Figs. 4B-C, the

carrier pin 412c resists the axial force. While the axial force is less than the static force provided by the carrier pin 412c, the pusher member 320 remains coupled with the carrier member 310.

5 As the axial force increases to a level that is greater than or substantially equal to the static force, the carrier pin 412c is displaced from the carrier slot 422c, decoupling the pusher member 320 from the carrier member 310. Thereby, the carrier member 310 preferably is inhibited from further distal movement and remains substantially stationary; whereas, the pusher member 320 proceeds distally to deploy the closure element 500 and to activate the locator release system 490 (shown in Fig. 10 4D) such that the distal end region 210b, the expansion elements 230, and/or the substantially flexible members 230' of the locator assembly 200 transition from the expanded state to the unexpanded state. Preferably, the axial force that is applied to overcome the static force associated with the first predetermined position is sufficient to overcome the static forces associated with the subsequent predetermined positions, 15 to deploy the closure element 500, and to activate the locator release system 490 such that the triggering system 400 operates in one substantially-continuous motion.

It will be appreciated that the triggering system 400 can include an energy storing element (not shown), which can be disposed substantially between the housing 380 and the blocks 410, 420, 430, and 440 and which is configured to store potential 20 energy for moving the tube set 305 from the initial predetermined position through the other predetermined positions, deploying the closure element 500, and/or activating the locator release system 490. The energy-storing element is configured store the potential energy when the tube set 305 is in the initial predetermined position and to release the potential energy, when activated, such that the tube set 305 travels through 25 the predetermined positions at a substantially constant and continuous rate. For example, the energy-storing element can comprise one or more springs (not shown). Each of the springs can be in a compressed state when the tube set 305 is in the initial predetermined position and released from the compressed state when the switching system 450 of the triggering system 400 is activated.

30 In use, the closure element 500 is disposed within the carrier assembly and adjacent to the distal end of the pusher tube 320. As shown in Figs. 7A-B, for example, the reduced closure element 500' can be slidably received over the distally-increasing cross-section 318b of the distal end region 310b of the carrier member 310

and disposed about the periphery 312 of the carrier member 310 adjacent to the space 360. Since the reduced cross-section 530' of the reduced closure element 500' is less than the cross-section 318b of the distally-increasing cross-section 318b, the reduced closure element 500' must be temporarily radially deformed to be received over the distal end region 310b. Also, as the reduced closure element 500' is received over the distal end region 310b, the opposing tines 520 of the reduced closure element 500' engages the distal end region 310b. The reduced closure element 500' thereby forms the substantially tubular closure element 500'' in the manner described in more detail above with reference to Figs. 6E-G.

After being received over the distal end region 310b, the substantially tubular closure element 500'' is disposed about the space 360, and the tines 520 are directed substantially distally as shown in Fig. 7B. As desired, one or more of the tines 520 can be disposed proximally of the distally-increasing cross-section 318b of the distal end region 310b, as illustrated in Fig. 7B, and/or can be at least partially disposed upon, and contact, the distally-increasing cross-section 318b of the distal end region 310b. To improve the engagement between the closure element 500 (shown in Figs. 6A-B) and the blood vessel wall 620 and/or tissue 630 (collectively shown in Fig. 8A), the substantially tubular closure element 500'' preferably is disposed on the carrier member 310 such that the tines 520 define a first plane that is substantially perpendicular to a second plane defined by the switching system 450 and/or the handles 390 (collectively shown in Fig. 5A).

Once disposed about the space 360, the substantially tubular closure element 500'' can be retained on the outer periphery 312b of the carrier member 310 when distal end region 310b of the carrier member 310 and the distal end region 320b of the pusher member 320 are slidably received within the lumen 334 of the cover member 330 as illustrated in Figs. 7C-D. When the cover member 330 is properly positioned within the carrier assembly 300, the distal end region 330b of the cover member 330 extends over the space 360 and defines the annular cavity 370 for retaining the substantially tubular closure element 500''. As such, the substantially tubular closure element 500'' is disposed substantially between the outer periphery 312b of the carrier member 310 and the inner periphery 332a of the cover member 330 such that the substantially tubular closure element 500'' maintains the substantially tubular configuration with the tines 520 being directed substantially

distally. As desired, the cover member 330 may radially compress the substantially tubular closure element 500" such that the substantially tubular closure element 500" enters and maintains a compressed tubular configuration. The body 510 of the substantially tubular closure element 500" can be disposed distally of the distal end region 320b of the pusher member 320, as illustrated in Figs. 7C-D, or can engage the distal end region 320b, as desired.

Turning to Fig. 8A, a sheath 640 may be inserted or otherwise positioned through skin 650 and tissue 630 and within the blood vessel 600 or other body lumen via the opening 610. Comprising a substantially flexible or semi-rigid tubular member, the sheath 640 has a proximal end region 640a and a distal end region 640b and includes a predetermined length and a predetermined cross-section, both of which can be of any suitable dimension. The sheath 640 also forms a lumen 644 that extends along a longitudinal axis of the sheath 640 and substantially between the proximal and distal end regions 640a, 640b. The lumen 644 can have any suitable internal cross-section 648b and is suitable for receiving one or more devices (not shown), such as a catheter, a guide wire, or the like. The lumen 644 is configured to slidably receive the tubular body 210 of the locator assembly 200 (shown in Fig. 4A) and/or the tube set 305 of the carrier assembly 300 (shown in Fig. 4A).

Since the internal cross-section 648b of the sheath 640 typically is less than or substantially equal to the predetermined cross-section 338b of the cover member 330, the sheath 640 may be configured to radially expand, such as by stretching, to receive the tube set 305. Alternatively, or in addition, the sheath 640 can be advantageously configured to split as the tube set 305 is received by, and advances within, the lumen 644 of the sheath 640, thereby permitting the apparatus 100 to access the blood vessel wall 620. To facilitate the splitting, the sheath 640 can include one or more splits 645, such as longitudinal splits, each split being provided in the manner known in the art. Each split 645 is configured to split the sheath 640 in accordance with a predetermined pattern, such as in a spiral pattern. It will be appreciated that, when the internal cross-section 648b of the sheath 640 is greater than the predetermined cross-section 338b of the cover member 330, it may not be necessary for the sheath 640 to be configured to radially expand and/or split. In addition to, or as an alternative to, the apparatus 100 may include a cutting means that

initiates a tear line or split in the sheath when the sheath is engaged with the distal end of the apparatus 100.

The sheath 640 may be advanced over a guide wire or other rail (not shown) which has been positioned through the opening 610 and into the blood vessel 600 using conventional procedures such as those described above. Preferably, the blood vessel 600 is a peripheral blood vessel, such as a femoral or carotid artery, although other body lumens may be accessed using the sheath 640 as will be appreciated by those skilled in the art. The opening 610, and consequently the sheath 640, may be oriented with respect to the blood vessel 600 such as to facilitate the introduction of devices through the lumen 644 of the sheath 640 and into the blood vessel 600 with minimal risk of damage to the blood vessel 600. One or more devices (not shown), such as a catheter, a guide wire, or the like, may be inserted through the sheath 640 and advanced to a preselected location within the patient's body. For example, the devices may be used to perform a therapeutic or diagnostic procedure, such as angioplasty, atherectomy, stent implantation, and the like, within the patient's vasculature.

After the procedure is completed, the devices are removed from the sheath 640, and the apparatus 100 is prepared to be received by the lumen 644 of the sheath 640 as shown in Fig. 8B. Being in the unexpanded state, the distal end region 210b of the tubular body 210 of the locator assembly 200 is slidably received by the lumen 644 and atraumatically advanced distally into the blood vessel 600 as illustrated in Figs. 8B-C. Once the distal end region 210b of the tubular body 210 extends into the blood vessel 600, the distal end region 210b can transition from the unexpanded state to the expanded state as shown in Fig. 8D by activating the switching system of the locator assembly 200.

Turning to Fig. 8E, the apparatus 100 and the sheath 640 then are retracted proximally until the distal end region 210b is substantially adjacent to an inner surface 620b of the blood vessel wall 620. The distal end region 210b thereby draws the blood vessel wall 620 taut and maintains the proper position of the apparatus 100 as the blood vessel 600 pulsates. Since the expanded cross-section of the distal end region 210b is greater than or substantially equal to the cross-section of the opening 610 and/or the cross-section of the lumen 644, the distal end region 210b remains in the blood vessel 600 and engages the inner surface 620b of the blood vessel wall 620.

The distal end region 210b can frictionally engage the inner surface 620b of the blood vessel wall 620, thereby securing the apparatus 100 to the blood vessel 600. The sheath 640 is retracted proximally such that the distal end region 640b of the sheath 640 is substantially withdrawn from the blood vessel 600, as shown in Fig. E, 5 permitting the apparatus 100 to access the blood vessel wall 620.

As the apparatus 100 is being retracted, the apparatus 100 preferably also is axially rotated such that the first plane defined by the tines 520 of the substantially tubular closure element 500" is substantially parallel with a third plane defined by the blood vessel 600. Thereby, the engagement between the substantially tubular closure 10 element 500" and the blood vessel wall 620 and/or tissue 630 can be improved because the tines 520 are configured to engage the blood vessel wall 620 and/or tissue 630 at opposite sides of the opening 610. If the substantially tubular closure element 500" is disposed on the carrier member 310 such that the first plane defined by the tines 520 is substantially perpendicular to the second plane defined by the switching 15 system 450 and/or the handles 390 (collectively shown in Fig. 5A), for example, the apparatus 100 can be positioned such that the second plane defined by the switching system 450 and/or the handles 390 is substantially perpendicular to the third plane defined by the blood vessel 600.

Once the distal end region 210b of the locator assembly 200 contacts the 20 inner surface 620b of the blood vessel wall 620, the tube set 305 can then be advanced distally and received within the lumen 644 of the sheath 640 as illustrated in Fig. 8F. In the manner described in more detail above with reference to Fig. 8A, the sheath 640 can radially expand and/or split in accordance with the predetermined pattern as the tube set 305 advances because the internal cross-section 648b of the sheath 640 is 25 less than or substantially equal to the predetermined cross-section 338b of the cover member 330. Being coupled, the carrier member 310, the pusher member 320, the cover member 330, and the support member 340 each advance distally and approach the first predetermined position as illustrated in Fig. 8G.

Upon reaching the first predetermined position, the tube set 305 is 30 disposed substantially adjacent to the outer surface 620a of the blood vessel wall 620 adjacent to the opening 610 such that the blood vessel wall 620 adjacent to the opening 610 is disposed substantially between the expanded distal region 210b of the locator assembly 200 and the tube set 305. The cover member 330 and the support

member 340 each decouple from the carrier member 310 and the pusher member 320 in the manner described in more detail above with reference to Figs. 5A-C when the tube set 305 is in the first predetermined position. Thereby, the cover member 330 and the support member 340 preferably are inhibited from further axial movement and remain substantially stationary as the carrier member 310 and the pusher member 320 each remain coupled and axially slidable.

As shown in Fig. 8H, the cover member 330 and the support member 340 remaining substantially stationary while the carrier member 310 and the pusher member 320 continue distally and approach the second predetermined position. As the carrier member 310 and the pusher member 320 distally advance toward the second predetermined position, the annular cavity 370 moves distally relative to the substantially-stationary cover member 330 such that the distal end region 330b of the cover member 330 no longer encloses the annular cavity 370. Thereby, the substantially tubular closure element 500" is not completely enclosed by the annular cavity 370 formed by the distal end regions 310b, 320b, and 330b of the carrier member 310, the pusher member 320, and the cover member 330.

Although not completely enclosed by the annular cavity 370, the substantially tubular closure element 500" is advantageously retained on the outer periphery 312b of the carrier member 310 by the distal end region 330b of the cover member 330 as illustrated in Fig. 8H. For example, by retaining the substantially tubular closure element 500" between the distal end region 330b of the cover member 330 and the distal end region 310b the carrier member 310, the apparatus 100 is configured to provide better tissue penetration. The timing between the deployment of the substantially tubular closure element 500" by the tube set 305 and the retraction and transition to the unexpanded state by the locator assembly 200 likewise is facilitated because the substantially tubular closure element 500" is retained between the distal end region 330b and the distal end region 310b. Further, the carrier member 310 and the cover member 330 operate to maintain the substantially tubular closure element 500" in the tubular configuration.

When the tube set 305 is in the second predetermined position, the carrier member 310 decouples from the pusher member 320 in the manner described in more detail above with reference to Figs. 5A-C. Therefore, the carrier member 310, the cover member 330, and the support member 340 preferably are inhibited from further

axial movement and remain substantially stationary; whereas, the pusher member 320 remains axially slidable. As the pusher member 320 continues distally, the distal end region 320b of the pusher member 320 contacts the substantially tubular closure element 500'' and displaces the substantially tubular closure element 500'' from the space 360 as shown in Fig. 8I. Since the space 360 is substantially radially exposed, the pusher member 320 directs the substantially tubular closure element 500'' over the distally-increasing cross-section of the distal end region 310b of the substantially-stationary carrier member 310 such that the cross-section 530' (shown in Figs. 6F-G) of the substantially tubular closure element 500'' begins to radially expand, preferably in a substantially uniform manner. As the substantially tubular closure element 500'' traverses the distally-increasing cross-section of the distal end region 310b, the cross-section 530' of the substantially tubular closure element 500'' radially expands beyond natural cross-section 530 (shown in Figs. 6A-B) of the closure element 500.

Upon being directed over the distally-increasing cross-section of the distal end region 310b by the pusher member 320, the substantially tubular closure element 500'' is distally deployed as illustrated in Fig. 8J. When the substantially tubular closure element 500'' is deployed, the tines 520 can pierce and otherwise engage significant amount of the blood vessel wall 620 and/or tissue 630 adjacent to the opening 610. For example, the tines 520 can engage a significant amount of the blood vessel wall 620 and/or tissue 630 because the cross-section 530' of the substantially tubular closure element 500'' is expanded beyond natural cross-section 530 of the closure element 500 during deployment.

As the closure element is being deployed from the space 360, the locator assembly 200 also begins to retract proximally and the locator release system 490 (shown in Fig. 4D) can be activated to transition from the expanded state to the unexpanded state as the substantially tubular closure element 500'' is deployed as shown in Fig. 8J. Preferably, the distal end region 210b of the locator assembly 200 retracts proximally and transitions from the expanded state to the unexpanded state substantially simultaneously with the deployment of the substantially tubular closure element 500''. As desired, the distal end region 210b may be configured to draw the blood vessel wall 620 and/or tissue 630 adjacent to the opening 610 proximally and into the channel 540 defined by the substantially tubular closure element 500''. The tines 520 of the substantially tubular closure element 500'' thereby can pierce and

otherwise engage the drawn blood vessel wall 620 and/or tissue 630. Since the cross-section 530' of the substantially tubular closure element 500'' is expanded beyond natural cross-section 530 of the closure element 500, a significant amount of the blood vessel wall 620 and/or tissue 630 can be drawn into the channel 540 and engaged by the tines 520.

Turning to Fig. 8K, the substantially tubular closure element 500', once deployed, begins to transition from the tubular configuration, returning to the natural, planar configuration with opposing tines 520 and a natural cross-section 530 of the closure element 500. Preferably, the substantially tubular closure element 500'' substantially uniformly transitions from the tubular configuration to the natural, planar configuration. Rotating axially inwardly to form the opposing tines 520 of the closure element 500, the tines 520 draw the tissue 630 into the channel 540 as the substantially tubular closure element 500'' forms the closure element 500. Also, the tissue 630 is drawn substantially closed and/or sealed as the cross-section 530' of the substantially tubular closure element 500'' contracts to return to the natural cross-section 530 of the closure element 500. Thereby, the opening 610 in the blood vessel wall 620 can be drawn substantially closed and/or sealed via the closure element 500 as illustrated in Fig. 8L.

It will be appreciated that the closure element 500 may be constructed of other materials, that it may comprise alternative shapes, and that it may adopt alternative methods of operation such that the closure element 500 achieves closure of openings in blood vessel walls or other body tissue. In an additional non-limiting example, the closure element 500 is constructed of materials that use a magnetic force to couple a pair of securing elements in order to close an opening in the lumen wall or tissue. In this alternative embodiment, the closure element 500 may be of a unitary or multi-component construction having a first securing element positionable at a first position adjacent the opening, and a second securing element positionable at a second position adjacent the opening. The first and second securing elements are provided having a magnetic force biasing the first and second securing elements together, thereby closing the opening, or they are provided having a magnetic force biasing both the first and second securing elements toward a third securing element positioned in a manner to cause closure of the opening. The magnetic closure element 500 may be provided without tines 520, provided the magnetic force coupling the closure

elements is sufficient to close the opening. Alternatively, the closure element 500 may be provided with a combination of the magnetic securing elements and tines 520 to provide a combination of coupling forces. Those skilled in the art will recognize that other and further materials, methods, and combinations may be utilized to
5 construct the closure element 500 to achieve the objectives described and implied herein.

It will be appreciated that the distal end region 380b of the housing 380 can be configured to couple with an introducer sheath 700 as shown in Fig. 9. Comprising a substantially flexible or semi-rigid tubular member, the introducer
10 sheath 700 has a proximal end region 700a and a distal end region 700b and includes a predetermined length and a predetermined cross-section, both of which can be of any suitable dimension. The distal end region 700b is configured to facilitate insertion of the introducer sheath 700 through tissue and/or into the opening 610 (shown in Fig. 8A) formed in and/or adjacent to the wall 620 (shown in Fig. 8A) of
15 the blood vessel 600 (shown in Fig. 8A) or other body lumen. For example, the distal end region 430b can have a tapered tip (not shown) for facilitating substantially atraumatic introduction of the introducer sheath 700 through a passage formed in the tissue 630 and/or at least partially into the blood vessel wall 620, which is accessible via the passage.

20 The introducer sheath 700 also forms a lumen 704 that extends along a longitudinal axis of the introducer sheath 700 and substantially between the proximal and distal end regions 700a, 700b. The lumen 704 can have any suitable length 708a and internal cross-section 708b and is configured to slidably receive the tubular body 210 of the locator assembly 200 (shown in Fig. 4A) and/or the tube set 305 of the
25 carrier assembly 300 (shown in Fig. 4A). Since the internal cross-section 708b of the introducer sheath 700 typically is less than or substantially equal to the predetermined cross-section 338b of the cover member 330, the introducer sheath 700 may be configured to radially expand, such as by stretching, to receive the tube set 305. Alternatively, or in addition, the introducer sheath 700 can be advantageously
30 configured to split as the tube set 305 is received by, and advances within, the lumen 704 of the introducer sheath 700 in the manner described in more detail above with reference to the sheath 640 (shown in Fig. 8A). To facilitate the splitting, the introducer sheath 700 can include one or more splits (not shown), such as longitudinal

splits, each split being provided in the manner known in the art. Each split is configured to split the introducer sheath 700 in accordance with a predetermined pattern, such as in a spiral pattern. It will be appreciated that, when the internal cross-section 708b of the introducer sheath 700 is greater than the predetermined cross-section 338b of the cover member 330, it may not be necessary for the introducer sheath 700 to be configured to radially expand and/or split.

The introducer sheath 700 can be coupled with the housing 380 via one or more cooperating connectors (not shown) such that the lumen 704 is substantially axially aligned with the tubular body 210 of the locator assembly 200 and/or the tube set 305 of the carrier assembly 300 and, as desired, may be removably and/or substantially permanently coupled with the housing 380. For example, a hub assembly 710 can be coupled with the proximal end region 700a of the introducer sheath 700. The proximal end region 430a of the introducer sheath 700 is coupled with, or otherwise provided on, a distal end region 710b of the hub assembly 710, such as via an adhesive, one or more cooperating connectors, and/or a thermo-mechanical joint.

The hub assembly 710 also includes a proximal end region 710a, which provides the one or more mating connectors for coupling the introducer sheath 700 with the housing 380 and forms a lumen (not shown), which extends substantially between the proximal end region 710a and the distal end region 710b. The lumen of the hub assembly 710 preferably has an internal cross-section or size that is greater than the internal cross-section or size of the lumen 704 of the introducer sheath 700. When the proximal end region 710a of the lumen 704 is properly connected with the hub assembly 710, the lumen of the hub assembly 710 is configured to communicate with the lumen 704 of the introducer sheath 700. As desired, the proximal end region 700a of the introducer sheath 700 may be flared to facilitate the connection between the introducer sheath 700 and the hub assembly 710.

When properly assembled, the hub assembly 710 preferably is substantially fluid tight such that the one or more devices can be inserted into the lumen 704 of the introducer sheath 700 without fluid passing proximally through the lumen 704. The hub assembly 710 can be made to be watertight, such as via one or more seals (not shown) and/or valves (not shown) in the manner known in the art. For example, the hub assembly 710 can include a thrust washer and/or valve, a guide

for directing the devices into the lumen 704 of the introducer sheath 700, and/or a seal (collectively not shown). The various seals and/or guides can be coupled with the hub assembly 710 via, for example, one or more spacers and/or end caps (also collectively not shown).

5 As desired, the hub assembly 710 further can include one or more side ports 720. The side ports 720 can communicate with the lumen of the hub assembly 710 and/or the lumen 704 of the introducer sheath 700. At least one of the side ports 720 can be configured to be connected with, and to communicate with, tubing (not shown) to, for example, infuse fluids into the lumen 704 and through the introducer
10 sheath 700. Alternatively, or in addition, at least one of the side ports 720 can provide a “bleed back” indicator, such as in the manner disclosed in the co-pending application Serial No. 09/680,837. The disclosures of this reference and any others cited therein are expressly incorporated herein by reference.

 An alternative embodiment of the apparatus is shown in Figs. 10-15. The
15 embodiment of Figs. 10-15 has many identical or similar structures that perform identical or similar functions to the embodiment described above and in reference to the preceding Figures. In the description of the alternative embodiment below, and in Figs. 10-15, components of the apparatus that are identical or substantially correspond to those previously described will bear the same reference numerals identified above
20 with the addition of the prime (‘) identifier.

 Turning to Figs. 10 and 11, the locator assembly 200’ is substantially similar to the structure described above in reference to Figs. 2A-D, including a flexible or semi-rigid tubular body 210’ (such as an elongate rail) with a longitudinal axis. The tubular body 210’ has a proximal end region 210a’ and a distal end region
25 210b’ and includes a predetermined length 218a’ and a predetermined outer cross-section, both of which can be of any suitable dimension. The distal end region 210b’ of the locator assembly 200’ preferably includes a substantially rounded, soft, and/or flexible distal end or tip 220’ to facilitate atraumatic advancement and/or retraction of the distal end region 210b’ into the blood vessel 600. As desired, a pigtail (not
30 shown) may be provided on the distal end 220’ to further aid atraumatic advancement of the distal end region 210b’.

 The distal end region 210b’ of the locator assembly 200’ further is selectably controllable between an unexpanded state and an expanded state, in the

manner described above in relation to Figs. 2A-D. In the alternative embodiment shown in Figs. 10A-B, the distal end region is shown in its expanded state, wherein the substantially flexible members 230' of the expansion elements 230' are flexed outward.

5 A control member 250', such as a rod, wire, or other elongate member, can be moveably disposed within a lumen (not shown) formed by the tubular body 210' and extending substantially between the proximal end region 210a' and the distal end region 210b'. The control member 250' has a proximal end region 250a' that is coupled with a control block 260', and a distal end region that is coupled with the
10 distal end region 210b' of the locator assembly 200', the expansion elements 230', and/or the movable end regions 230c' of the substantially flexible members 230'. The control block 260' is preferably of a tubular shape and formed of a metal or rigid plastic, and is adapted to be retained in a control block cavity 265' (see Fig. 10B) formed on the internal surface of the housing bottom half 380d', to thereby maintain
15 the control block 260' in a substantially fixed position relative to the housing 380'. The locator control system can selectively transition the distal end region 210b', the expansion elements 230', and/or the substantially flexible members 230' between the unexpanded and expanded states by moving the tubular body 210' axially relative to the control member 250'.

20 Formed on the proximal end 210a' of the tubular body 210' is a tubular body block 270' having a proximal groove 271'. The tubular body block 270' is formed of metal, rigid plastic, or other substantially rigid material and is preferably formed integrally with or attached securely to the tubular body 210'. The proximal groove 271' and the proximal end of the tubular body block 270' have a shape
25 adapted to cooperate with a pair of tabs 281a'-b' formed on a locator assembly block 280' whereby the tubular body block 270' is maintained in a fixed axial relationship with the locator assembly block 280'. In this way, the tubular body block 270' and tubular body 210' are advanced distally by distal advancement of the locator assembly block 280'.

30 A locator assembly spring 290' is located coaxially with and substantially surrounds a portion of the tubular body block 270'. The locator assembly spring 290' is located between and contacts the distal side of two of the tabs 281a formed on the locator assembly block 280', and the proximal side of a locator assembly spring stop

381' formed on the inner surface of the housing bottom half 380d' (see Fig. 10B). The locator assembly spring 290' so located provides a force biasing the locator assembly block 280' in the proximal direction relative to the housing 380'.

The locator assembly block 280' is preferably formed of metal, plastic, or other rigid material. A function of the locator assembly block 280' is to allow the user to apply a force causing distal movement of the tubular body 210' relative to the control member 250' to cause the locator assembly 200' to transition from the unexpanded state to the expanded state. The proximal end of the locator assembly block 280' has a slot 281' formed therein, the slot 281' preferably having a size sufficient to accommodate the control block 260' and the control block cavity 265', and to allow the locator assembly block 280' to travel axially relative to the housing 380'. The distal end of the locator assembly block 280' has a pair of distally extending forks 282a-b, with each of the forks 282a-b having a ramp 283a-b on its inward facing surface. Finally, the locator assembly block 280' has a pair of distally extending release tabs 284a-b, with each of the release tabs 284a-b having a detent 285a-b.

As shown in Figs. 11A-B, the locator assembly block 280' is slidably received and retained within grooves formed in the proximal end of the housing 380', with the proximal end of the locator assembly block extending from the proximal end of the housing. The control block 260' and control block cavity 265 are located in the slot 281' formed in the proximal end of the locator assembly block 280'.

The locator release system 490' performs the function of releasing the locator assembly 200', thereby allowing the locator assembly 200' to transition from its expanded state to its unexpanded state. Turning to Figs. 10A-B and Fig. 15, the locator release system 490' of the alternative embodiment of the apparatus includes a locator release rod 491' having a release tab spacer block 492' formed on its proximal end. The locator release rod 491' and release tab spacer block 492' are received and retained in a groove formed on the interior surface of the housing bottom half 380d. The release tab spacer block 492' is preferably integrally formed with or attached to the proximal end of the locator release rod 491', and is formed of metal, plastic, or other rigid material. As shown in Fig. 15, the release tab spacer block 492' has a shape and size adapted to fit between the release tabs 284a-b formed on the locator assembly block 280', thereby biasing the release tabs 284a-b outward and causing the

outward facing detents 285a-b to engage a pair of retaining grooves 286a-b formed on the interior of the housing 380'. As long as the detents 285a-b are thus engaged with the retaining grooves 286a-b of the housing 380', the locator assembly block 280' is held in its axial position against the spring force imparted in the proximal direction by the locator assembly spring 290'. The distal end of the locator release rod 491' has an engagement member 493' that, in the preferred embodiment, comprises an inward bend on the distal end of the locator release rod. As described more fully below, the engagement member 493' on the locator release rod 491' is preferably positioned within the apparatus such that, when the closure element 500 is delivered, the engagement member 493' is engaged and caused to move axially in the distal direction, thereby disengaging the release tab spacer block 492' from the locator assembly block 280' and causing the locator assembly simultaneously to transition from its expanded state to the unexpanded state.

The alternative embodiment of the apparatus 100' includes a carrier assembly 300' that is coupled with, and slidable relative to, the locator assembly 200'. The carrier assembly 300' is configured to receive and retain the closure element 500 (shown in Figs. 6A-B), which preferably is disposed substantially within the carrier assembly 300'. When the locator assembly 200' engages the inner surface 620b (shown in Fig. 8A) of the blood vessel wall 620 (shown in Fig. 8A), the carrier assembly 300' is further configured to position the closure element 500 substantially adjacent to the opening 610 and to deploy the closure element 500, as described elsewhere herein.

Turning to Figs. 10A-B, the carrier assembly 300' includes a tube set comprising a carrier member 310', a pusher member 320', a cover member 330', and a support member 340'. The carrier member 310', pusher member 320', cover member 330', and support member 340' are preferably provided as a plurality of nested, telescoping members with a common longitudinal axis. The carrier member 310' is configured to receive and support the closure element 500. While being disposed on the carrier member 310', the closure element 500 preferably is deformed from the natural, planar configuration to form the substantially tubular closure element 500" (shown in Figs. 6F-G) as described herein.

The carrier member 310' includes a proximal end region 310a' and a distal end region 310b'. The carrier member 310' can also define a lumen 314' that extends

substantially between the proximal end region 310a' and the distal end region 310b' and that is configured to slidably receive at least a portion of the tubular body 210' of the locator assembly 200' and/or the support member 340'. Although the exterior cross-section of the carrier member 310' is substantially uniform, the distal end region 310b' of the carrier member 310' preferably has a cross-section that increases distally, as illustrated in Figs. 10A-B, for substantially uniformly expanding the substantially tubular closure element 500" beyond the natural cross-section 530 of the closure element 500 when the substantially tubular closure element 500" is deployed. Alternatively, the distal end region 310b' may be formed with a uniform cross-section to deploy the closure element 500 without cross-sectional expansion.

The pusher member 320' has a proximal end region 320a' and a distal end region 320b' and is coupled with, and slidable relative to, the carrier member 310'. The pusher member 320' includes a predetermined length and a predetermined cross-section, both of which can be of any suitable dimension and can be configured to slidably receive the carrier member 310' such that the distal end region 320b' of the pusher member 320' is offset proximally from the distal end region 310b' of the carrier member 310'. As desired, the predetermined length of the pusher member 320' can be greater than or substantially equal to the predetermined length of the carrier member 310'. The predetermined length of the pusher member 320' preferably is less than the predetermined length of the carrier member 310' such that the carrier member 310' and the pusher member 320' at least partially define a space 360' distal to the distal end region 320b' of the pusher member 320' and along the periphery of the carrier member 310'.

The pusher member 320' preferably is substantially tubular and can define a lumen 324' that extends substantially between the proximal end region 320a' and the distal end region 320b' and that is configured to slidably receive at least a portion of the carrier member 310'. The cross-section of the pusher member 320' preferably is substantially uniform, and the distal end region 320b' of the pusher member 320' can comprise one or more longitudinal extensions 325', which extend distally from the pusher member 320' and along the periphery of the carrier member 310'. The longitudinal extensions 325' preferably are biased such that the longitudinal extensions 325' extend generally in parallel with the common longitudinal axis of the carrier assembly tube set. The longitudinal extensions 325' are sufficiently flexible to

expand radially, and yet sufficiently rigid to inhibit buckling, as the distal end region 320b' is directed distally along the carrier member 310' and engage the distally-increasing cross-section of the distal end region 310b' of the carrier member 310' to deploy the substantially tubular closure element 500".

5 The cover member 330' is configured to retain the substantially tubular closure element 500" substantially within the carrier assembly 300' prior to deployment. Being coupled with, and slidable relative to, the pusher member 320', the cover member 330' has a proximal end region 330a' and a distal end region 330b' and includes a predetermined length and a predetermined cross-section, both of which
10 can be of any suitable dimension. Preferably being formed as a substantially rigid, semi-rigid, or flexible tubular member, the cover member 330' has an inner periphery and an outer periphery and can define a lumen 334'. The lumen 334' extends substantially between the proximal and distal end regions 330a', 330b' of the cover member 330' and can be configured to slidably receive at least a portion of the pusher
15 member 320'. When the cover member 330' is properly positioned within the carrier assembly 300', the distal end region 330b' is configured to extend over the space 360', thereby defining an annular cavity 370' for receiving and retaining the substantially tubular closure element 500".

 The cross-section of the cover member 330' preferably is substantially
20 uniform, and the distal end region 330b' of the cover member 330' preferably comprises one or more longitudinal extensions 335', which extend distally from the cover member 330' and along an outer periphery of the pusher member 320' (see Fig. 3D). Although the longitudinal extensions 335' can extend generally in parallel with common longitudinal axis 350', the longitudinal extensions 335' preferably are biased
25 such that the plurality of longitudinal extensions 335' extend substantially radially inwardly as illustrated in Figs. 3A and 3D. Thereby, the longitudinal extensions 335' can at least partially close the lumen 334' substantially adjacent to the distal end region 330b' of the cover member 330'. To permit the substantially tubular closure element 500" to be deployed from the annular cavity 370', the longitudinal extensions
30 335' preferably are sufficiently flexible to expand radially to permit the distal end region 310b' of the carrier member 310' to move distally past the cover member 330' to open the annular cavity 370' such that the distal end region 330b' no longer extends over the space 360'.

If the carrier assembly 300' is assembled as the plurality of nested, telescoping members as shown in Fig. 3A, the carrier member 310' is at least partially disposed within, and slidable relative to, the lumen 324' of the pusher member 320'. The support member 340' is slidable relative to the pusher member 310'. The pusher member 320', in turn, is at least partially disposed within, and slidable relative to, the lumen 334' of the cover member 330'. To couple the carrier assembly 300' with the locator assembly 200', the tubular body 210' of the locator assembly 200' is at least partially disposed within, and slidable relative to, the lumen 314' of the carrier member 310'. The longitudinal axis of the locator assembly 200' preferably is substantially in axial alignment with the common longitudinal axis of the carrier member 310', the pusher member 320', and the cover member 330'.

The tube set 305 preferably also includes a support member 340' as shown in Figs. 10A-B. The support member 340' is configured to slidably receive the tubular body 210' of the locator assembly 200' and to provide radial support for the distal end region 210b' of the tubular body 210' when the locator assembly 200' is coupled with the carrier assembly 300'. The carrier assembly 300' can advantageously include the support member 340', for example, if the tubular body 210' is not sufficiently rigid or under other circumstances in which support for the tubular body 210' might be desirable. It also will be appreciated that the support member 340' also can be configured to inhibit the plurality of longitudinal extensions 335', which extend from the distal end region 330b' of the cover member 330', from expanding prematurely when the closure element 500 is deployed. If the longitudinal extensions 335' were to expand prematurely, they may become hung up on the introducer sheath 640 or other delivery member (in an introducer sheath or delivery member is used), the tissue 630, or the wall 620 of the blood vessel. This may interfere with the proper advancement or other movement of the cover member 330' and the carrier assembly 300'.

Preferably being formed as a substantially rigid, semi-rigid, or flexible tubular member, the support member 340' includes a proximal end region 340a' and a distal end region 340b'. Having an outer periphery, the support member 340' can define a lumen 344' that extends substantially between the proximal end region 340a' and the distal end region 340b' and that is configured to slidably receive and support at least a portion of the tubular body 210' of the locator assembly 200'. The support

member 340', in turn, can be at least partially slidably disposed within the lumen 314' of the carrier member 310' such that the tubular body 210' of the locator assembly 200' is coupled with, and slidable relative to, the carrier member 310' in the manner described in more detail above. The support member 340' has a predetermined length and a predetermined cross-section, both of which can be of any suitable dimension, and the cross-section preferably is substantially uniform. Although shown and described as being substantially separate for purposes of illustration, it will be appreciated that the carrier member 310', the pusher member 320', the cover member 330', and/or the support member 340' can be provided, in whole or in part, as one or more integrated assemblies.

The carrier assembly 300' also can include a housing 380', the top half 380c of which is illustrated in Fig. 10A, and the bottom half 380d of which is shown in Fig. 10B. Preferably being formed as an elongate member with a longitudinal axis, the housing 380' has an outer periphery and includes a proximal end region 380a' and a distal end region 380b'. Thereby, when the apparatus 100' is properly assembled, the tubular body 210' of the locator assembly 200' is at least partially disposed within, and slidable relative to, the tube set 305 such that the distal end region 210b' of the tubular body 210' extends beyond the distal end regions 310b', 320b', 330b', and/or 340b'. The tubular body 210', the carrier member 310', the pusher member 320', the cover member 330', and, if provided, the support member 340' are at least partially disposed within, and slidable relative to, the housing 380', and the respective distal end regions 210b', 310b', 320b', 330b', and 340b' extend from the distal end region 380b' of the housing 380' such that the common longitudinal axis 350' of the tube set 305 is substantially axially aligned with the longitudinal axis 386' of the housing 380'. Being configured to slidably retain the respective proximal end regions 210a', 310a', 320a', 330a', and 340a', the housing 380' supports the tube set 305 and can have one or more handles 391', 392' to facilitate use of the apparatus 100'. The handles 391', 392' extend substantially radially from the outer periphery of the housing 380' and can be provided in the manner known in the art.

When the apparatus 100' is properly assembled, the tubular body 210' of the locator assembly 200' is at least partially disposed within, and slidable relative to, the tube set 305 of the carrier assembly 300' such that the distal end region 210b' of the tubular body 210' extends beyond the distal end regions 310b', 320b', 330b',

and/or 340b'. Further, the proximal end region 210a' of the tubular body 210' and the proximal end regions 310a', 320a', 330a', and/or 340a' of the tube set 305 are at least partially disposed within, and slidable relative to, the housing 380'. The switching system of the locator assembly 200' and a switching system of the triggering system 400' preferably are accessible external to the housing 380' as shown in Figs. 11-15.

As shown in Figs. 11-15, the triggering system 400' of the alternative embodiment of the apparatus 100' can be disposed substantially within the housing 380'. The triggering system 400' is configured to control the relative axial movement and/or positioning of the respective distal end regions 310b', 320b', 330b', and 340b' of the tube set 305 and/or the distal end region 210b' of the locator assembly 200'. Axial motion of one or more of the carrier member 310', the pusher member 320', the cover member 330', and the support member 340' and/or the tubular body 210' can be attained, for example, by applying an axial force to the switching system 405'.

The triggering system 400' includes a set of block members – a carrier block 410', a pusher block 420', a cover block 430', and a support block 440' – each of which is formed integrally with or securely attached to its respective member of the carrier assembly 300'. The block members are adapted to selectably couple and decouple the carrier member 310', the pusher member 320', the cover member 330', and the support member 340' relative to one another in order to provide axial movement of those components in a predetermined manner intended to deliver the closure element 500 in the manner described herein. For example, when the carrier assembly 300' reaches a first predetermined distal position, the support member 340' can be decoupled from the carrier member 310', the pusher member 320', and the cover member 330' and is thereafter substantially inhibited from further axial movement. Thereby, the carrier member 310', the pusher member 320', and the cover member 330' may be directed distally as the support member 340' remain substantially stationary. Subsequently, the carrier member 310' and the cover member 330' can be decoupled from the pusher member 320' and thereafter inhibited from further axial movement. Thereby, the pusher member 320' may be directed distally as the support member 340', carrier member 310', and cover member 330' remain substantially stationary, as described more fully herein.

The carrier block 410' is disposed on the proximal end region 310a' of the carrier member 310' and includes a trigger extension 405' that extends through a slot

in the housing 380' to the exterior of the housing 380' to be accessible to the user. The carrier block 410' includes a pair of grooves 413a-b formed on a peripheral surface of the carrier block 410', the grooves 413a-b being adapted to receive and retain a pair of tabs 445a-b formed on a pair of forks 444a-b extending distally from the support block 440', thereby selectably coupling the support block 440' to the carrier block 410'. The carrier block 410' also includes a pair of distal tabs 416a-b extending from the distal end of the carrier block 410', and adapted to engage a pair of slots 423a-b formed on the proximal end of the pusher block 420'.

The carrier block 410' also includes a pair of forks 414a-b extending in the proximal direction from the proximal end of the carrier block, each of the forks having an outward directed tab 415a-b at its proximal end. The tabs 415a-b are adapted to selectably engage a pair of slots 387a-b (not shown) formed on the interior surface of the housing 380' near its proximal end and, when so engaged, to fix the axial position of the carrier block 410' and, with it, the carrier assembly 300' relative to the housing 380'. The tabs 415a-b are disengaged from the slots in the housing when the locator assembly block 280' is moved axially in the distal direction in the following manner (see Fig. 11B). As the locator assembly block 280' is advanced distally, the interior surfaces of the ramps 283a-b on the locator assembly block forks 282a-b engage the exterior surfaces of the tabs 415a-b and cause the carrier block forks 414a-b to flex inward, releasing the tabs 415a-b from the slots in the housing, thereby freeing the carrier block 410' and the carrier assembly 300' to move axially. Thus, axial movement of the carrier block 410' within the apparatus is inhibited until the locator assembly block 280' is advanced to transition the locator assembly 200' to the expanded condition, simultaneously releasing the tabs 415a-b on the carrier block 410'.

The pusher block 420' is disposed on the proximal end region 320a' of the pusher member 320'. As described above, the pusher block 420' includes a pair of slots 423a-b formed on its proximal end that are adapted to selectably engage the pair of distal tabs 416a-b extending from the distal end of the carrier block 410'. The pusher block 420' also includes a pair of grooves 424a-b formed on its peripheral surface, the grooves 424a-b being adapted to engage a pair of tabs 435a-b formed on a pair of forks 434a-b extending from the proximal side of the cover block 430' to selectably couple the cover block 430' to the pusher block 420'.

The cover block 430' is disposed on the proximal end region 330a' of the cover member 330'. As described above, the cover block 430' includes a pair of forks 424a-b extending from the proximal end of the cover block 430', each of the forks having an inward directed tab 435a-b that are adapted to engage the grooves 424a-b on the peripheral surface of the pusher block 420' to selectably couple the cover block 430' to the pusher block 420'.

The support block 440' is disposed on the proximal end region 340a' of the support member 340'. As described above, the support block includes a pair of forks 444a-b extending from the distal end of the support block 440', each of the forks having an inward directed tab 445a-b that are adapted to engage the grooves 413a-b formed on the surface of the carrier block 410' to selectably couple the support block 440' to the carrier block 410'.

The carrier block 410', pusher block 420', cover block 430', and support block 440' are shown in Figs. 11-13 in their fully coupled state, with the support block 440' coupled to the carrier block 410', the pusher block 420' coupled to the carrier block 410', and the cover block 430' coupled to the pusher block 420'. In this arrangement, the carrier assembly 300' comprises a coaxial set of tubes (as shown, for example, in Fig. 3A), with the support member 340' slidably retained substantially within the carrier member 310', which is in turn slidably retained substantially within the pusher member 320', which is in turn slidably retained substantially within the cover member 330'.

The triggering system 400' of the alternative embodiment of the apparatus includes an energy storing element that is used in the final stage of the closure element 500 delivery process. The energy storing element, preferably a spring such as the pusher spring 425' shown in Figs. 10A-B, is substantially retained in a spring cavity 417' formed in the carrier block 410' and coaxially surrounds a proximal portion 310a' of the carrier member 310'. The pusher spring 425' is capable of expanding and contracting, storing potential energy as it is contracted and releasing energy as it expands. In its fully expanded state, the pusher spring 425' has a length that is greater than the length of the spring cavity 417'. The cross-sectional dimension of the pusher spring 425' is such that it backs up against and contacts the proximal end of the pusher block 420'. Thus, when the pusher spring 425' is in place between the carrier block 410' and the pusher block 420', the pusher spring 425' is

capable of imparting a force biasing the carrier block 410' away from the pusher block 420'.

Prior to delivery of the closure element 500, the distal end of the carrier block 410' is in physical contact with the proximal end of the pusher block 420'. In this pre-delivery condition, the pusher spring 425' is in a contracted state and is maintained fully within the spring cavity 417' formed in the carrier block 410'. A catch member 418' serves the function of maintaining the carrier block 410' and pusher block 420' in the pre-delivery condition against the spring force of the pusher spring 425', the force of which would otherwise force apart the carrier block 410' from the pusher block 420'. The catch member 418' is a U-shaped piece of metal, plastic, or other rigid material that engages a first groove 418a formed on the surface of the carrier block 410' and a second groove 418b formed on the surface of the pusher block 420'. The pusher block 420' includes a hole 426' extending through a portion thereof, with one end of the hole 426' opening into the groove 418b. The hole 426' is adapted to receive a trip pin 427'. During the closure element deployment process, the trip pin 427' is advanced through the hole 426', where it encounters the catch member 418' that is retained in the groove 418b. Further advancement of the trip pin 427' causes the catch member 418' to become disengaged from the groove 418b, thereby releasing the restraining force on the pusher spring 425'.

The operation of the triggering system 400' of the alternative embodiment of the apparatus 100' is illustrated in Figs. 11-14 with the closure element 500 (shown in Figs. 6A-B) disposed substantially within the apparatus 100'. As shown in Figs. 11A-B, the apparatus has an initial position in which the locator assembly block 280' is extended proximally and the triggering system 400' is in its most proximal position. Accordingly, the locator control system 200' is in its unexpanded state, as shown. At a point in time that the distal end region 210b' of the locator assembly 200' has been positioned as desired (for example, within the blood vessel 600), the locator assembly block 280 is depressed distally, as shown in Fig. 12, thereby transitioning the locator assembly to the expanded state and, simultaneously, releasing the triggering system 400' from the initial position (in the manner described above) such that the triggering system can be advanced distally within the housing 380'.

The triggering system 400' is then advanced distally within the housing 380', thereby advancing the tube set 305 into position adjacent the blood vessel. At a

first predetermined position, shown in Fig. 13, the support block 440' encounters a support stop (not shown) on the interior surface of the housing bottom half 380d that inhibits the support block 440' from advancing further distally. As a result, an application of additional distal force to the triggering system 400' causes the support block 440' to decouple from the carrier block 410', as shown in Fig. 13. More specifically, the tabs 445a-b on the forks 444a-b of the support block 440' disengage from the grooves 413a-b on the carrier block 410'. Thus, the support block 440' remains in the position shown in Fig. 13, while the carrier block 410' is able to advance further distally upon application of force to the triggering system 400'.

Turning to Figs. 14A-B, as the triggering system 400' is advanced further distally, the cover block 430' engages a cover stop on the interior surface near the distal end of the housing 380', thereby inhibiting additional distal advancement of the cover block 430'. In addition, the trigger extension 405' engages the handle 391' on the exterior of the apparatus, thereby inhibiting additional distal advancement of the carrier block 410'. At this point, the distal end of the tube set corresponds generally to the state illustrated in Fig. 8G, prior to deployment of the closure element 500.

The closure element 500 is next deployed by releasing the pusher spring 425', which causes the pusher block 420' (and, thus, the pusher member 320') to advance distally, deploying the closure element in the manner described above. The pusher spring 425' is released by disengaging the catch member 418' from the groove 418b on the pusher block 420', thereby releasing the pusher spring 425' to force the pusher block 420' and, thus, the pusher member 320' – distally relative to the carrier block 410'. This action causes the pusher member 320' to deploy the closure element 500, as shown, for example, in Figs. 8H-L. The catch member 418' is disengaged from the groove 418b by applying a force to the trigger 401', which, in the deployment position, is aligned with the trip pin 427' retained in the pusher block 420'. A trigger spring 402' biases the trigger outward relative to the housing 380'. The user applies an inward directed force to the trigger 401' to counteract the biasing force of the trigger spring 402' and force the trigger 401' against the trip pin 427'.

In addition to deploying the closure element 500, the distal advancement of the pusher block 420' also causes the locator release system 490' to activate, thereby transitioning the locator control system 200' from the expanded state to the unexpanded state. As the pusher block 420' advances distally to deploy the closure

element 500' in the manner described above, the pusher block 420' also engages the engagement member 493' of the locator release system 490' and advances the locator release rod 491' distally. This action causes the release tab spacer block 492' to disengage from the release tabs 284a-b on the locator assembly block 280' (see Fig. 5 15), thereby releasing the locator assembly block 280', which returns to its proximal position, causing the locator assembly 200' to return to the unexpanded state. The closure element 500 deployment and locator release actions occur nearly simultaneously, as illustrated in Figs. 8I-K.

As described previously, the apparatus 100 is preferably brought into 10 contact with the blood vessel 600 by inserting and advancing the distal end of the apparatus through an introducer sheath 640 to the blood vessel location. Although preferred, the use of an introducer sheath 640 is not necessary, as the apparatus can be used to deploy the closure element 500 without the use of an introducer sheath 640. Furthermore, as describe above, when an introducer sheath 640 is used, the locator 15 assembly 200, 200' and the carrier assembly 300, 300' may have cross-sectional dimensions that allow them to be received within the introducer sheath 640 either without causing radial expansion or splitting of the sheath, or with causing radial expansion or splitting of the sheath. If the relative cross-sectional dimensions of the introducer sheath 640 and carrier assembly 300, 300' are such that the introducer 20 sheath 640 is intended to be split during advancement of the carrier assembly 300, 200', a sheath cutter 701' having a pointed tip 702' may be utilized to initiate a split at the proximal end of the introducer sheath 640. The sheath cutter 701' is advantageously placed coaxially over the cover member 330' and is attached to the distal end of the housing 380' (see Figs. 11A-B), whereby it will initiate a split in the 25 introducer sheath 640. Distal advancement of the carrier assembly 300, 300' causes the initial split at the proximal end of the sheath to advance as the carrier assembly 300, 300' advances, as will be understood by those skilled in the art.

Another alternative embodiment of an apparatus for sealing openings through tissue is shown in Figs. 16-19. The embodiment of Figs. 16-19, as described 30 below, has many identical or similar structures that perform identical or similar functions to the embodiments described above and in reference to the preceding Figures. Accordingly, the description below should be considered in view of the descriptions above of the preceding embodiments. Furthermore, those of ordinary

skill in the art will appreciate that one or more of the components and/or features of the embodiment shown in Figs. 16-19 may also be incorporated in the previously described embodiments, as those components and/or features of the previously described embodiments may optionally be incorporated in the embodiment described
5 below and in reference to Figs. 16-19.

Turning to Figs. 16 and 16A, the device 1001 is particularly adapted for use in conjunction with a guidewire in an over the wire deployment method described below. The device 1001 has a generally elongated body that includes, beginning at its proximal end, an actuator cap 1280, a generally cylindrical actuator housing 1800, a
10 generally cylindrical release barrel 1810, a generally cylindrical main housing 1380, and a distal extension 1010. Several components of a locator assembly, a carrier assembly, and a triggering system are contained within the main housing 1380, as described more fully below in relation to Figs. 18 and 19. The distal extension 1010 of the device includes an external protective sheath 1012 that covers the distal
15 portions of the locator assembly and carrier assembly. The distal end region 1210b of the locator assembly extends out of the distal end of the protective sheath 1012.

With particular reference to Fig. 16A, the distal end region 1210b of the locator assembly includes expansion elements 1230 that include substantially flexible members 1230'. The substantially flexible members 1230' are able to be selectively
20 controllable between and unexpanded state (as shown in Fig. 16A) and an expanded state, generally in the manner described above in relation to Figs. 2A-D. As shown in Fig. 16A, the locator assembly of the alternative embodiment of the device 1001 is provided with a central lumen 1003, which is preferably of a diameter sufficient to accommodate a standard guidewire or other structure, as appropriate. As described
25 below, the central lumen 1003 extends through the length of the locator assembly and, thus, through the length of the device 1001.

Turning again to Fig. 16, the main housing 1380 includes a pair of grips 1392a-b integrally formed on opposite sides of the main housing 1380. The distal end of the main housing 1380 is gradually tapered 1382, with the protective sheath 1012
30 extending out of its distal end. A cylindrical counter spring 1386 is located coaxially on the external surface of the main housing 1380 and rests, at its distal end, against a shoulder 1384 formed in the main housing just proximal to the section of the main housing upon which the grips 1392 are formed. The proximal end of the counter

spring 1386 rests against the release barrel 1810, biasing the release barrel 1810 proximally in relation to the shoulder 1384 formed on the main housing 1380. The release barrel 1810 is generally cylindrical and coaxially surrounds the main housing 1380. A mechanical linkage 1812 connects the release barrel 1810 to a release lever 1814 that cooperates with an actuator block 1282, as described more fully below in reference to Figs. 18 and 19. A longitudinal slot 1388 is formed on each of the main housing 1380 and the release barrel 1810, through which extends a lever 1405 that, as described below, is used to advance the carrier assembly in the distal direction to operate the device 1001.

A calibration set screw 1818 is located on the release barrel 1810 near the distal end of the slot 1388. As the user advances the lever 1405 distally to deploy the closure element 500 similar to that described above and shown in Figures 6a-6g, the lever 1405 will eventually engage the calibration set screw 1818. As described below, further distal advancement of the lever 1405 causes the actuator block 1282 to release, thereby causing the locator assembly to release the expansion elements 1230 and 1230' from the expanded state to the unexpanded state. Thus, the setting of the calibration set screw 1818 allows the user to fine tune the synchronization of the release of the locator assembly with the deployment of the closure element 500, as described below.

The actuator housing 1800 is attached by a screw 1802 to the proximal end of the main housing 1380, and extends proximally from the main housing 1380. A longitudinal slot 1804 is formed in the actuator housing 1800 to accommodate the release lever 1814 and the linkage 1812 (see Figs. 18-19). The actuator cap 1280 extends out from the proximal end of the actuator housing 1800. The actuator cap 1280 is a generally cylindrical body that is coaxial with and generally internal of the actuator housing 1800. The actuator cap 1280 includes a slide seal 1288 at its proximal end that is slidable and that provides a fluid-tight seal, as described in more detail below. Additional details concerning the actuator are described below in reference to Figs. 18 and 19.

Turning to Figs. 17 and 17A, the proximal end of the device is shown in more detail. As shown, the slide seal 1288 on the actuator cap 1280 has been slid to an open position to expose the interior of the actuator. The slide seal 1288 is provided with a pair of tabs 1287 that cooperate with a pair of slots 1289 formed on the

proximal end of the actuator cap 1280 to allow the slide seal 1288 to slide in relation to the actuator cap 1280. The actuator cap 1280 includes a seal 1281, such as an o-ring, that provides a fluid tight seal with the slide seal 1288.

As described above and as shown in Figs. 17 and 17A, the central lumen 5 1003 extends longitudinally through the center of the device and is accessible at the proximal end of the actuator cap 1280 when the slide seal 1288 is in the open position. Additional details concerning the central lumen 1003 are described below in relation to the additional Figures.

Figure 17 provides additional detail concerning the shape and orientation 10 of the grips 1392 formed on the main housing. As shown, the grips 1392 extend radially outward on opposite sides of a point near the distal end of the main housing 1380, and provide the user with the ability to grip the housing with two fingers while operating the lever 1405 with the user's thumb. Also shown in Figs. 17 and 17A is the slot 1804 formed in the actuator housing 1800 to accommodate the release lever 15 1814.

Figures 18, 18A, and 18B show a cross-section of the proximal portion of the device 1001, including the previously described main housing 1380, the release barrel 1810 located coaxially in a slidable relation on the external surface of the main housing, the counter spring 1386 that biases the release barrel proximally relative to 20 the shoulder 1384 formed on the main housing, the actuator housing 1800 extending proximally from the proximal end of the main housing, the linkage 1812 and release lever 1814 connected to the release barrel 1810, and the actuator cap 1280 extending proximally from the proximal end of the actuator housing 1800. The actuator cap 1280 is attached to, or formed integrally with, an actuator block 1282 that is generally 25 cylindrical and that is adapted to slide longitudinally within an actuator base 1284. The actuator base 1284, in turn, is attached by the screw 1802 to the proximal end of the main housing 1380 and the distal end of the actuator housing 1800, as shown in Fig. 18.

The central lumen 1003 is shown extending through the length of the 30 device along its longitudinal axis. The central lumen 1003 is defined by the interior diameter of the tubular body 1210 of the locator assembly 1200, which extends from the proximal end region 1210a to a distal end region 1210b (see Fig. 16A). The proximal end region 1210a of the tubular body 1210 is attached or otherwise

connected to the actuator block 1282 such that when the actuator block 1282 is advanced distally the tubular body 1210 is also advanced distally, thereby causing the flexible members 1230' to buckle and/or expand transversely outwardly, (in the manner described above, for example, in relation to Figs. 2A-D), thereby transitioning the distal end region 1210b of the locator assembly 1200 from the unexpanded state to the expanded state. For example, in Fig. 18, the actuator cap 1280 is shown in the extended position, consistent with the locator assembly 1200 being in the unexpanded state. In Fig. 19, the actuator cap 1280 is shown in the depressed position, consistent with the locator assembly 1200 being in the expanded state. An actuator spring 1286 is located in a chamber 1285 formed within the interior of the device between the distal end of the actuator block 1282 and the actuator base 1284 attached to the proximal end of the main housing 1380 and the distal end of the actuator housing 1800. The actuator spring 1286 biases the actuator block 1282 in the proximal direction. Depressing the actuator cap 1280 causes the actuator spring 1286 to compress within the chamber 1285. Once the actuator cap is fully depressed, the release lever 1814 is rotated inwardly such that a catch 1816 formed on the release lever engages a slot 1283 formed on the actuator block 1282, thereby holding the actuator block 1282 in place in the depressed position against the spring force of the actuator spring 1286. The release lever 1814 may be disengaged, thus transitioning the locator assembly 1200 from the expanded state to the unexpanded state, either by manually releasing the release lever 1814 from the actuator block 1282 and allowing the actuator block to extend proximally, or by advancing the carrier assembly lever 1405 distally to engage the calibration set screw 1818 on the release barrel 1810 and applying additional distal force to the lever 1405 (and, thus, the release barrel 1810) to cause the release lever 1814 to disengage from the actuator block 1282.

A tube set 1305 is located within the interior of the main housing 1380, extending distally through the distal extension 1010. The tube set 1305 shown in Fig. 18 includes a carrier tube 1310, a pusher tube 1320, and a cover tube 1330, each located in a coaxial orientation with each other and with the tubular body 1210 of the locator assembly 1200. The tube set 1305 has a structure otherwise substantially identical to that described above in relation to Figs. 3A-E. The cover tube 1330 is connected or otherwise attached at its proximal end to a cover block 1430. The pusher tube 1320, similarly, is connected or otherwise attached at its proximal end to

a pusher block 1420. Finally, the carrier tube 1310 is connected or otherwise attached at its proximal end to a carrier block 1410. The lever 1405 is attached to the pusher block 1420. Thus, any movement of the lever 1405 will cause the pusher block 1420 to move as well.

5 A leaf spring 1418 connects the carrier block 1410 to the pusher block 1420, as shown in Fig. 18B. The leaf spring 1418 is generally flat and extends longitudinally parallel to the central axis of the device. A lip 1419 is formed on the distal end of the leaf spring 1418, the lip 1419 oriented such that it engages the distal end of the pusher block 1420, effectively locking the pusher block 1420 to the carrier
10 block 1410 until the leaf spring 1418 is disengaged from the pusher block 1420, as described below. As long as the pusher block 1420 is thereby locked to the carrier block 1410, advancement of the lever 1405 will cause advancement of the combination of the carrier block 1410 and the pusher block 1420.

 A guide pin 1900 is located and fixed on the interior of the main housing
15 1380, and extends proximally from the distal wall of the interior of the main housing. The guide pin 1900 is received within a slot 1902 formed in the pusher block 1420 and cover block 1430, and prevents the pusher block 1420 and cover block 1430 from rotating inside the main housing 1380.

 A grooved pin 1910 is also located and fixed on the interior of the main
20 housing 1380, and extends proximally from the distal wall of the interior of the main housing 1380. The grooved pin 1910 is preferably located on an opposite side of the interior of the main housing from the guide pin 1900. The grooved pin 1910 has a taper 1912 formed on its proximal end and a transverse groove 1914 formed just distally from the beginning of the taper 1912. The location and orientation of the
25 grooved pin 1910 are such that the taper 1912 formed on the grooved pin 1910 engages and lifts the leaf spring 1418 from its engagement with the pusher block 1420 as the pusher block 1420 and carrier block 1410 are advanced distally within the device. As the pusher block 1420 and carrier block 1410 are advanced still further, the lip 1419 formed on the leaf spring 1418 engages and locks in place in the
30 transverse groove 1914 formed on the grooved pin 1910, thereby preventing the carrier block 1410 (and, thus, the carrier tube 1310) from advancing any further distally. This position of the device also corresponds to the engagement of the lever 1405 with the calibration set screw 1818 (see Fig. 16). Any additional distal

movement of the lever 1405 will cause the pusher block 1420 to move further distally while the carrier block 1410 remains stationary, thus causing the pusher tube 1320 to deploy the closure element 1500, in the manner described above in relation to Figs. 8A-L. This additional distal movement of the lever 1405 also simultaneously causes
5 the release barrel 1810 to move distally and to disengage the release lever 1814 from the actuator block 1282, thereby releasing the actuator block 1282 and causing the locator assembly 1200 to transition from the expanded state to the unexpanded state.

Referring now to Figs. 20A-L, methods of use of the device 1001 in accordance with the present invention will be described. As previously described
10 above and shown in Figures 16-19, the device 1001 is configured to deploy a closure element 500 over a wire, wherein the over the wire deployment method utilizing the device 1001 described herein may for example include the following steps, though methods of use associated with the apparatus should not be limited to those described herein or shown in the appended drawings.

Referring now to Fig. 20A, there is shown a vessel 620 disposed below a
15 patient's tissue 630 and skin 650, wherein a guidewire 1950 is shown disposed through an opening formed in the vessel and tissue as described above. The guidewire 1950 may be introduced into the blood vessel for the sole purpose of using the device 1001 to deploy the closure element 500, or the guidewire may have already
20 been present from a previously completed interventional procedure. If an introducer sheath is in place, it should be removed prior to use of the apparatus 1001, thereby leaving the guidewire 1950 in place extending into the blood vessel.

As shown in Fig. 20B, the device 1001 is then threaded over the guidewire
25 1950 by inserting the proximal end of the guidewire 1950 into the central lumen of the device 1001 at the distal end of the device, the guidewire is disposed through the device and exits at the proximal end of the device. The device 1001 is then advanced along the guidewire until the distal end 210b of the locator assembly is disposed through the opening formed in the blood vessel as shown in Fig. 20C, whereby the correct position of the device is confirmed by observing a slight flow of blood out of
30 the proximal end of the device, through the open slide seal 1288 on the actuator cap 1280.

Once the correct position of the device is confirmed, the actuator cap 1280 is depressed (i.e., the actuator block 1282 is advanced distally) to deploy the flexible

members on the distal end 210b of the locator assembly, i.e., to transition the locator assembly from the unexpanded state to the expanded state. In the expanded state, the flexible members are able to engage the inside of the vessel wall at the location of the opening in the blood vessel as shown in Fig. 20D. The correct position of the device at this point may be confirmed by gently pulling on the device to feel the resistance of the vessel wall against the flexible members in the expanded state as shown in Fig. 20E. After verifying the correct position in this manner, the guidewire may be removed from the vessel and from the device by withdrawing the guidewire through the proximal end of the device. Once the guidewire is removed, the slide seal 1288 on the actuator cap 1280 may be closed to prevent further flow of blood through the device.

Referring now to Figs. 20F and 20G, the device 1001 is in proper position to deploy the closure element 500. The closure element 500 is deployed by advancing the lever 1405, which advances the carrier block 1410, pusher block 1420, and cover block 1430 until further distal advancement of the carrier block 1410 and cover block 1430 are prevented by the interaction of the leaf spring 1418 engaging and locking in place in the transverse groove 1914 formed on the grooved pin 1910, thereby preventing the carrier block 1410 (and, thus, the carrier tube 1310) from advancing any further distally. Further distal advancement of the lever 1405 thereafter causes advancement only of the pusher block 1420, which causes deployment of the closure element 500 in the identical manner described above, for example, in relation to Figs. 8H-L. In addition, further distal advancement of the lever 1405 causes the lever 1405 simultaneously to engage the release barrel 1810, which in turn pulls the release lever 1814 and frees the actuator block 1282 to spring back proximally, transitioning the locator assembly 1200 from the expanded state to the unexpanded state. The closure element deployment and locator release actions occur nearly simultaneously, as illustrated, for example, in Figs. 8I-K.

As shown in Figure 20G, the closure element 500 is shown in a deployed position, wherein the closure element has been engaged with the vessel wall to effectively close the opening formed therein. As previously described and shown in Figs. 20F and 20G, the closure element 500 is expanded as it is deployed from the device 1001, wherein by increasing the diameter of the closure element 500, the closure element may engage tissue adjacent the opening in the tissue. It is

contemplated that the closure element may be configured to penetrate the vessel wall to effect a closure, or partially penetrate the vessel wall to effect closure.

5 The invention is susceptible to various modifications and alternative forms, and specific examples thereof have been shown by way of example in the drawings and are herein described in detail. It should be understood, however, that the invention is not to be limited to the particular forms or methods disclosed, but to the contrary, the invention is to cover all modifications, equivalents, and alternatives falling within the spirit and scope of the claims.

CLAIMS

What is claimed is:

1. An apparatus for delivering a closure element to an opening formed in a wall of a body lumen or body tissue, comprising:

5 a backing member having a distal end region configured to extend into said opening and to selectably contact said wall of said body lumen or said body tissue adjacent to said opening;

a carrier assembly coupled with said backing member, said carrier assembly comprising a carrier member retaining said closure element in a substantially tubular configuration within said carrier assembly, and a pusher member adapted to deploy said closure element; and

10 a tubular member coupled with said carrier assembly and defining a lumen, said lumen adapted to receive a guidewire therein;

wherein said pusher member is adapted to move relative to said carrier member to deploy said closure element, and said closure element, when deployed, is configured to engage at least a portion of said wall of said body lumen or said body tissue whereby said opening is drawn substantially closed.

2. The apparatus of claim 1, wherein said backing member comprises a locator assembly that is selectably controllable between an unexpanded state and an expanded state for engaging said wall of said body lumen or said body tissue.

3. The apparatus of claim 2, wherein said distal end region of said locator assembly includes an expansion element configured to expand substantially transversely with respect to a longitudinal axis of the locator assembly.

4. The apparatus of claim 3, wherein said expansion element comprises a plurality of substantially flexible members each having a substantially fixed end region fixedly coupled with said distal end region of said locator assembly, an intermediate region, and a movable end region movable coupled with said distal end region of said locator assembly such that said intermediate regions are configured to expand transversely outwardly when said movable end regions are axially moved toward said substantially fixed end regions.

5. The apparatus of claim 4, wherein said locator assembly further includes a locator control system coupled to a proximal end region of said locator assembly, said locator control system being configured to selectively control said

distal end region of said locator assembly between said expanded state and said unexpanded state.

6. The apparatus of claim 1, wherein said carrier assembly comprises a carrier member for receiving and supporting said closure element in said substantially tubular configuration, a pusher member for distally deploying said closure element, and a cover member for retaining said closure element, said carrier member, said pusher member, and said cover member being slidably coupled.

7. The apparatus of claim 6, wherein said carrier member, said pusher member, and said cover member are provided as a plurality of nested, telescoping members with a common longitudinal axis.

8. The apparatus of claim 7, wherein said carrier member defines a lumen, said distal end region of said locator assembly being substantially axially aligned with, and at least partially slidably disposable within, said lumen of said carrier member.

9. The apparatus of claim 8, wherein said distal end region of said carrier member has a cross-section that increases distally for expanding said closure element to a cross-section that is greater than a natural cross-section of said closure element.

10. The apparatus of claim 9, wherein said distal end region of said pusher member includes one or more longitudinal extensions extending distally and being configured to expand radially as said distal end region of said pusher member moves distally and engages said distally-increasing cross-section of said distal end region of said carrier member.

11. The apparatus of claim 9, wherein said distal end region of said cover member includes one or more longitudinal extensions extending distally and being configured to expand radially.

12. The apparatus of claim 6, wherein said carrier assembly further includes a support member being slidably coupled with said carrier member, said pusher member, and said cover member and being configured to provide radial support for said distal end region of said cover member.

13. The apparatus of claim 12, wherein said carrier member, said pusher member, said cover member, and said support member are provided as a plurality of nested, telescoping members with a common longitudinal axis.

14. The apparatus of claim 1, further comprising an energy storing member associated with said carrier assembly, said energy storing member adapted to cause relative motion between said carrier member and said pusher member.

5 15. The apparatus of claim 14, wherein said energy storing member comprises a spring.

16. The apparatus of claim 15, wherein said spring is disposed substantially between said carrier member and said pusher member.

17. The apparatus of claim 16, wherein said spring is substantially disposed in a cavity located on one of said carrier member or said pusher member.

10 18. The apparatus of claim 16, further comprising a catch member adapted to selectably maintain said carrier member in proximity to said pusher member against a spring force imparted by said spring.

15 19. The apparatus of claim 18, further comprising a trigger selectably engageable with said catch member, said trigger adapted to cause said catch member to release said spring.

20. The apparatus of claim 2, wherein said tubular member is coupled with said backing member to comprise said locator assembly.

20 21. The apparatus of claim 1, further comprising a guidewire extending through said opening formed in the wall of the body lumen or body tissue and through the lumen in said tubular member.

22. A method for closing an opening formed in a wall of a body lumen or body tissue, comprising:

threading a closure element delivery device over a guidewire;

25 extending a backing member of the closure element delivery device into the opening in the wall of the body lumen or body tissue such that the backing member engages the wall of the body lumen or the body tissue adjacent to the opening;

30 positioning a distal end region of a carrier assembly of the closure element delivery device adjacent to said opening, said distal end region of said carrier assembly being configured to retain a closure element substantially within said carrier assembly; and

deploying said closure element from said carrier assembly such that said closure element engages at least a portion of said wall of said body lumen or said body tissue whereby said opening is drawn substantially closed.

23. The method of claim 22, wherein said deploying step comprises causing a pusher member of said carrier assembly to move relative to a carrier member of said carrier assembly to cause deployment of said closure element.

24. The method of claim 23, wherein said pusher member is caused to
5 move relative to said carrier member by an energy storing member associated with said carrier assembly.

25. The method of claim 24, wherein said energy storing member comprises a spring.

26. The method of claim 25, wherein said carrier assembly comprises a
10 carrier member retaining said closure element in a substantially tubular configuration within said carrier assembly, and a pusher member adapted to deploy closure element, and said spring is disposed substantially between said carrier member and said pusher member.

27. The method of claim 26, wherein said spring is substantially disposed
15 in a cavity located on one of said carrier member or said pusher member.

28. The method of claim 26, further comprising a catch member adapted to selectably maintain said carrier member in proximity to said pusher member against a spring force imparted by said spring.

29. The method of claim 28, further comprising a trigger selectably
20 engageable with said catch member, said trigger adapted to cause said catch member to release said spring.

30. The method of claim 22, wherein said closure element delivery device is extended through an introducer sheath during said positioning step.

31. The method of claim 30, wherein at least a portion of said introducer
25 sheath expands radially during said positioning step.

32. The method of claim 30, wherein no portion of said introducer sheath substantially expands radially during said positioning step.

33. The method of claim 30, wherein at least a portion of said introducer sheath splits during said positioning step.

30 34. The method of claim 30 wherein at least a portion of said introducer sheath splits as a result of said positioning step.

35. The method of claim 22, wherein said closure element is retained in said carrier assembly in a substantially tubular configuration.

36. The method of claim 35, wherein said closure element substantially uniformly expands to a cross-section that is greater than a natural cross-section of said closure element during said deploying step.

37. The method of claim 35, wherein said closure element maintains a substantially uniform cross-section during said deploying step.

38. The method of claim 35, wherein said closure element transitions to a natural, planar configuration during said deploying step.

10 39. The method of claim 22, wherein said carrier assembly is slidably coupled with said backing member.

40. The method of claim 39, wherein said backing member comprises a locator assembly having a distal end region adapted to extend into said opening and to selectably engage the wall of the body lumen or the body tissue adjacent to said opening.

15 41. The method of claim 40, wherein said distal end region of said locator assembly is selectably controllable between an unexpanded state and an expanded state for contacting said wall of said body lumen or said body tissue.

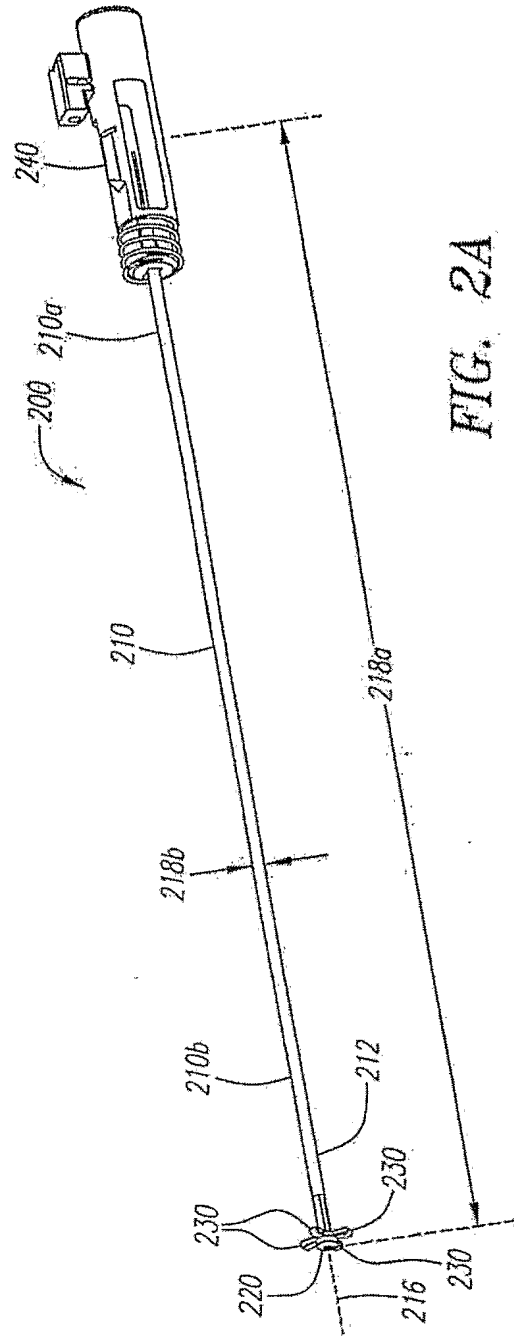
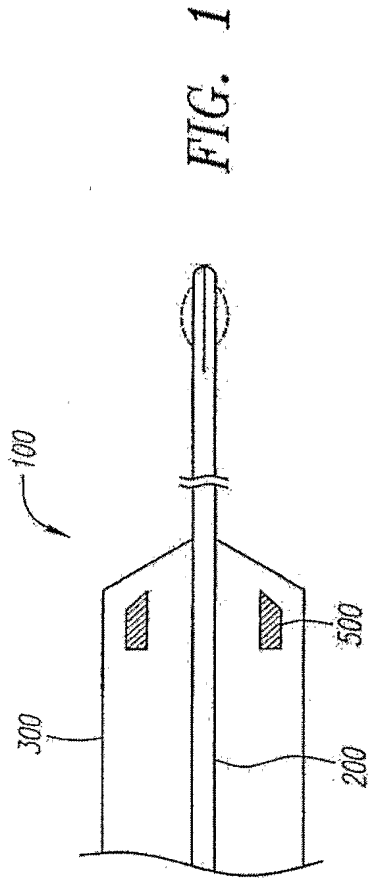

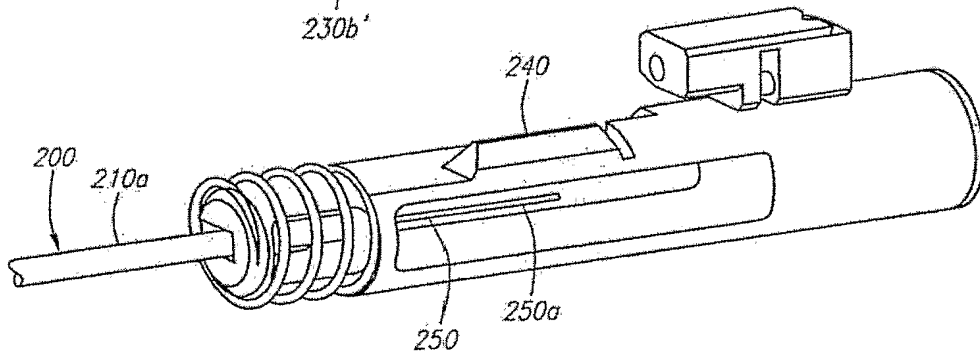
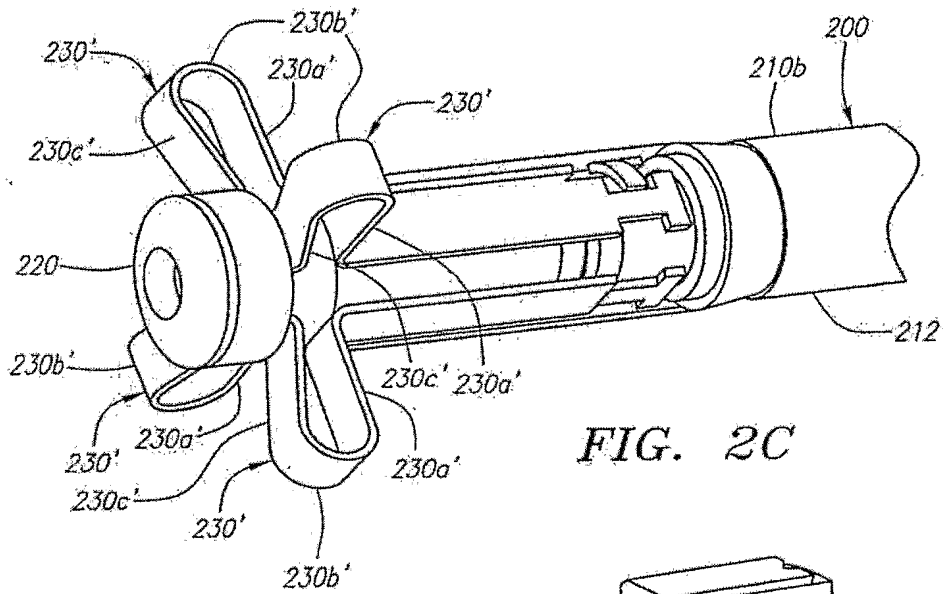
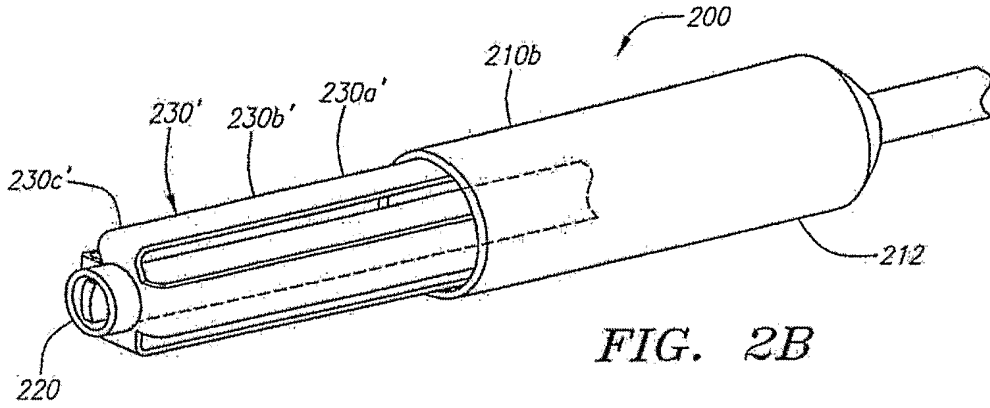

FIG. 2D

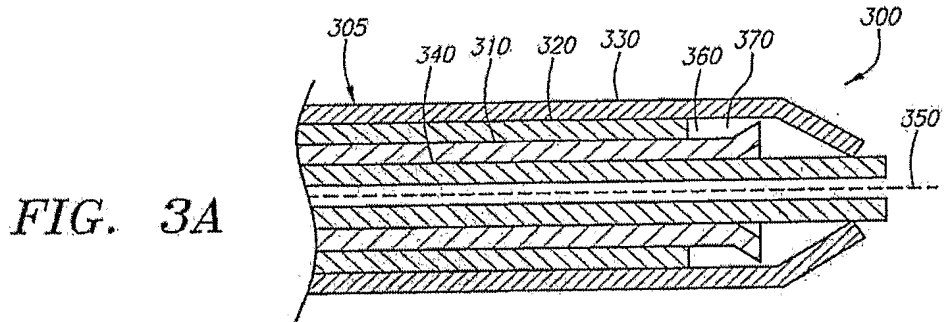

FIG. 3A

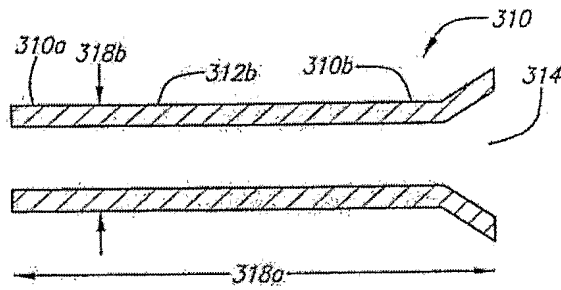

FIG. 3B

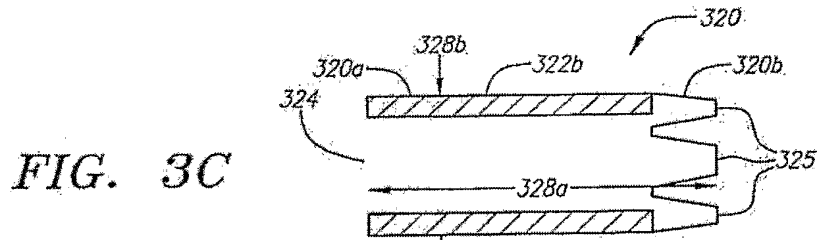

FIG. 3C

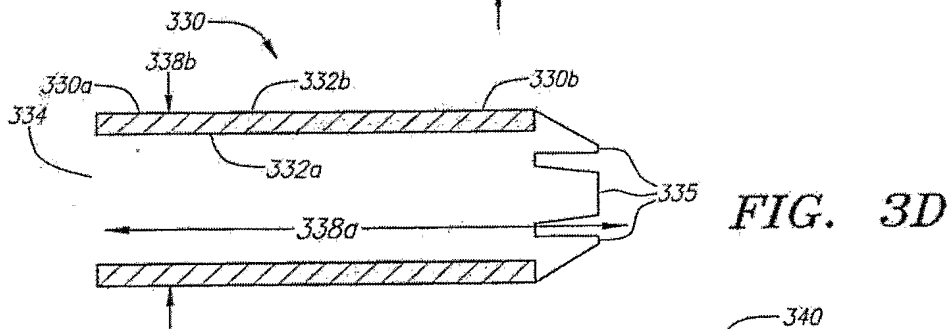

FIG. 3D

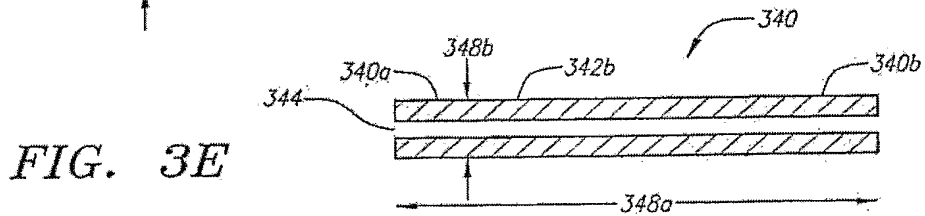

FIG. 3E

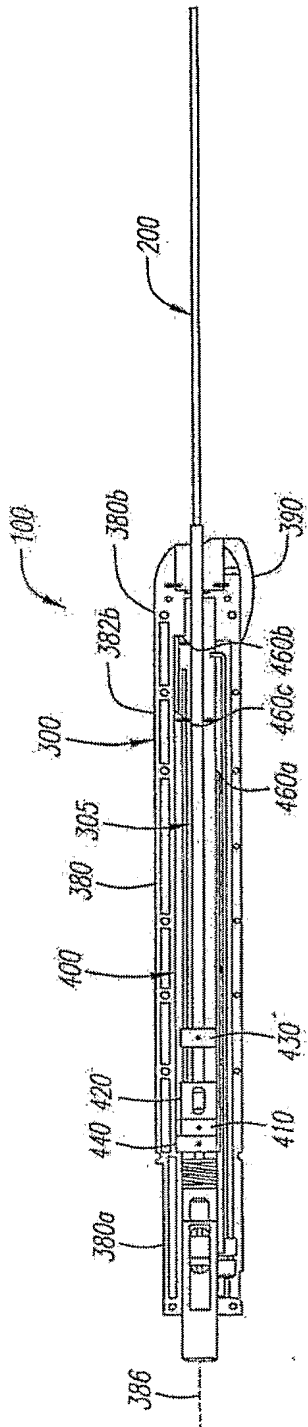

FIG. 4A

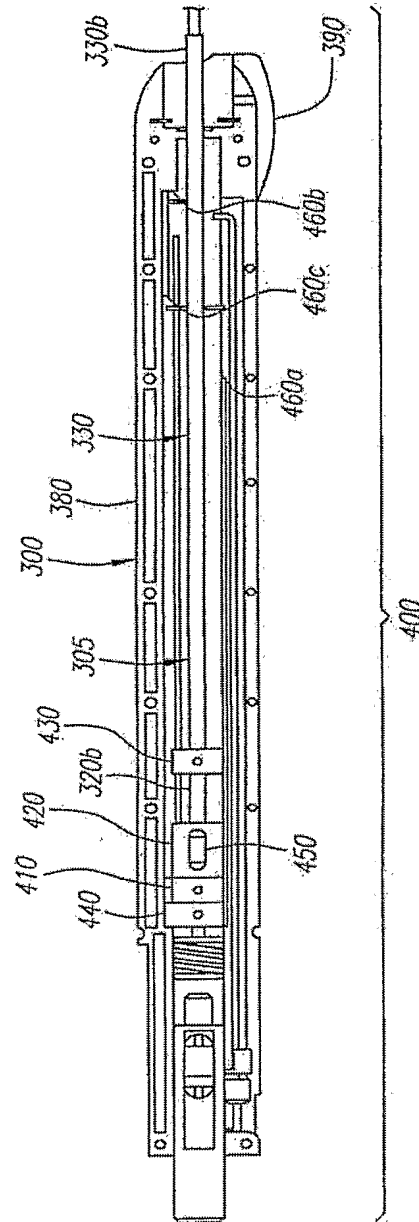

FIG. 4B

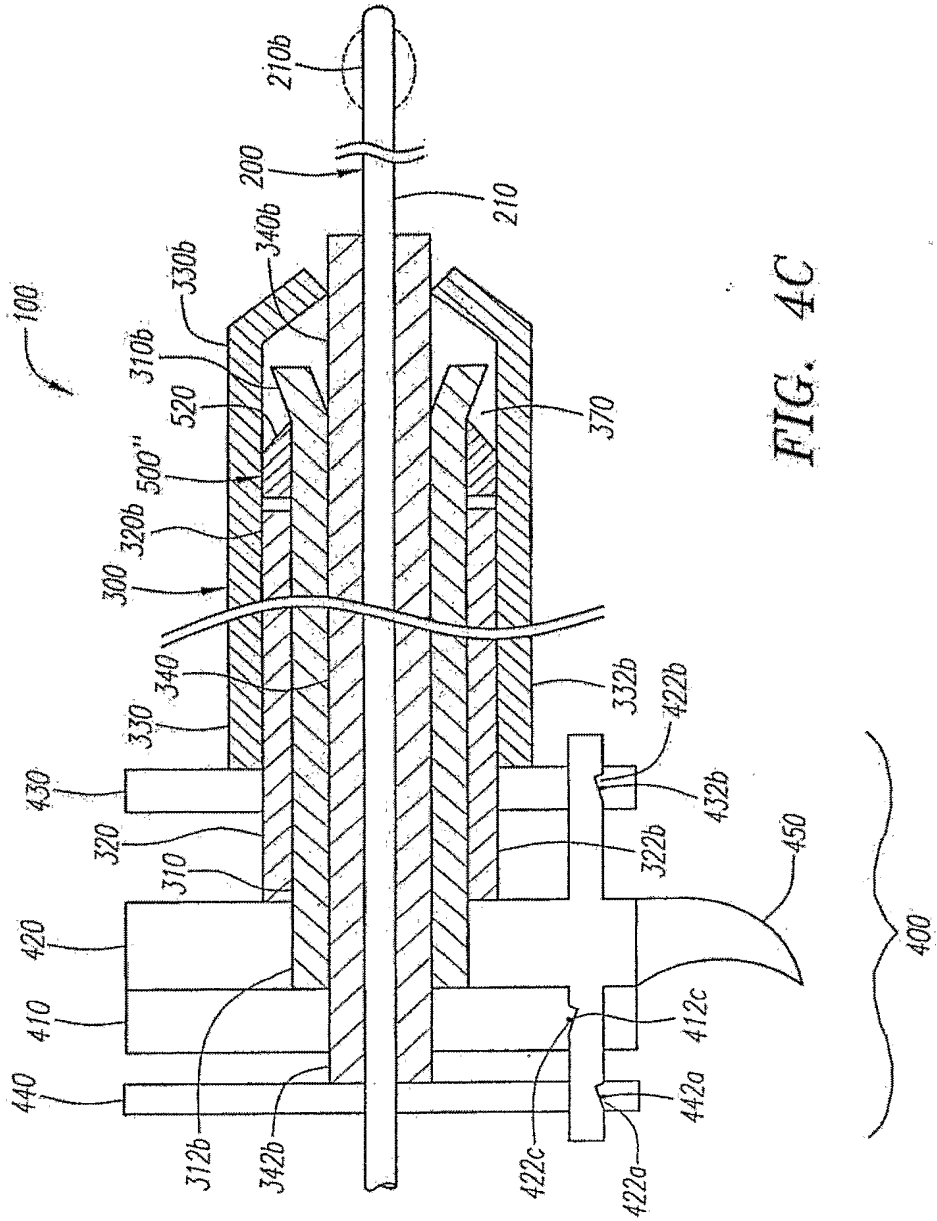

FIG. 4C

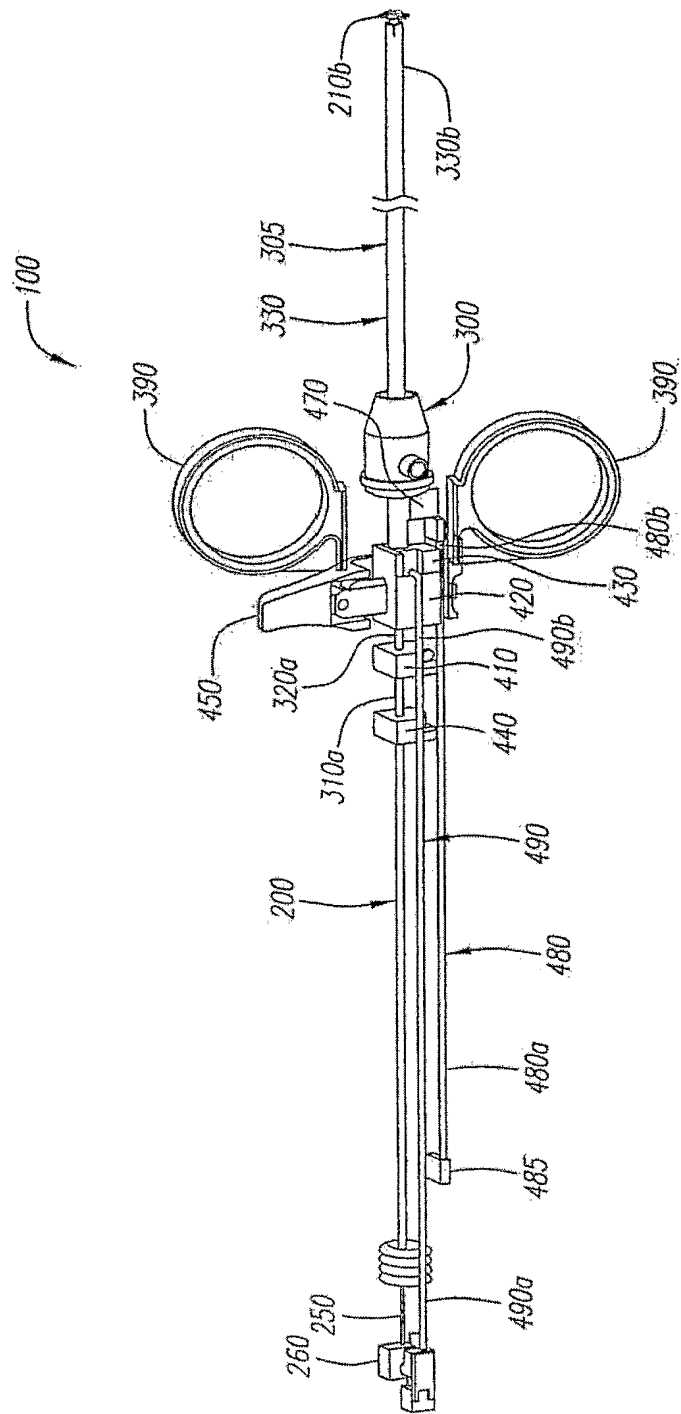

FIG. 4D

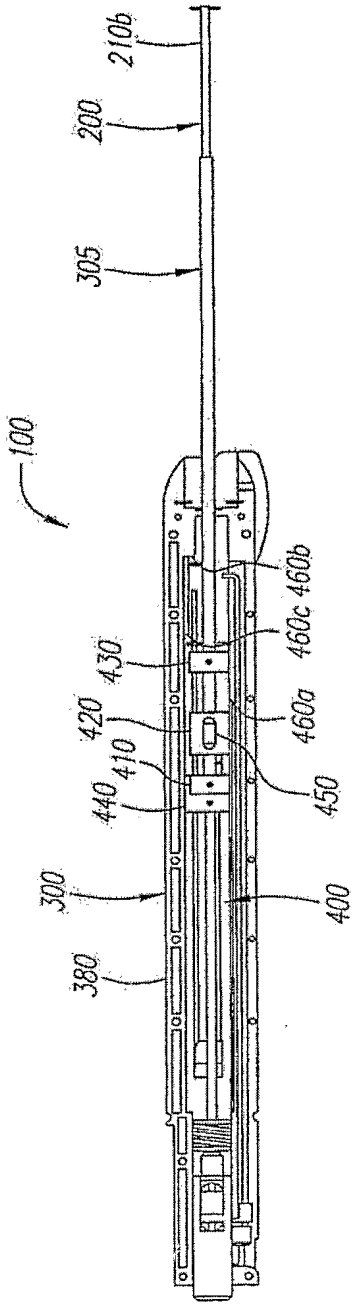

FIG. 5A

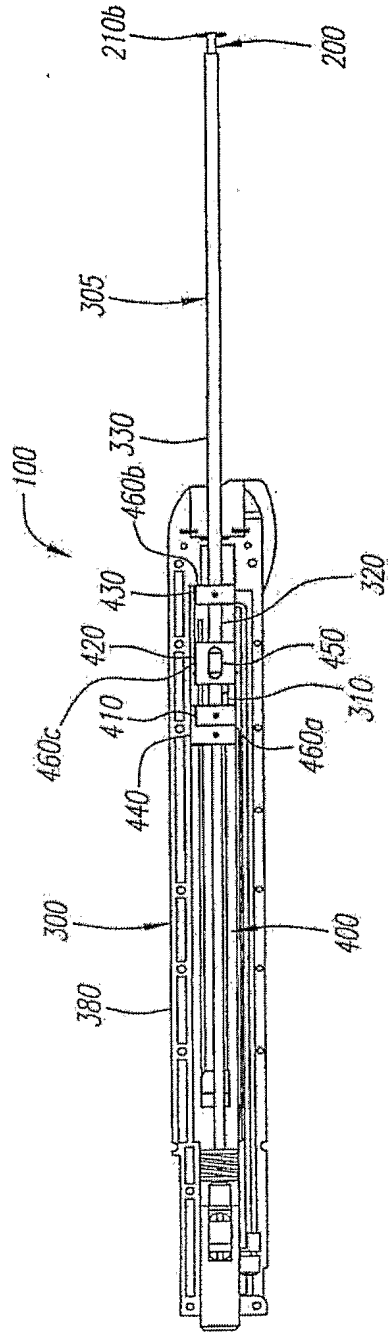

FIG. 5B

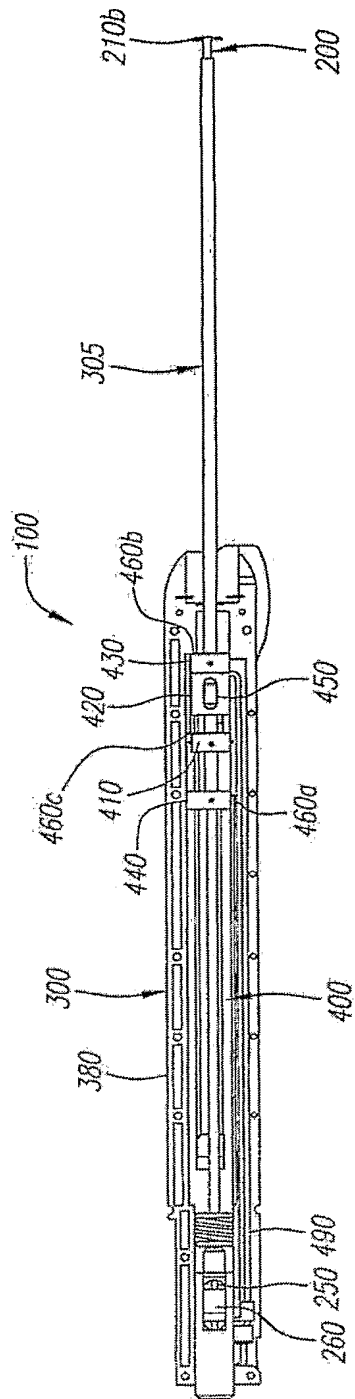

FIG. 5C

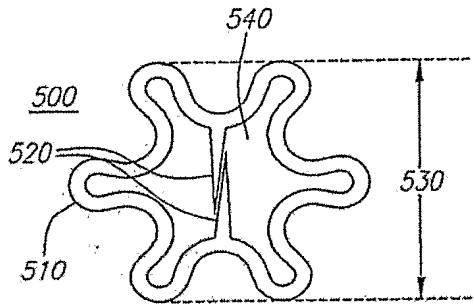

FIG. 6A

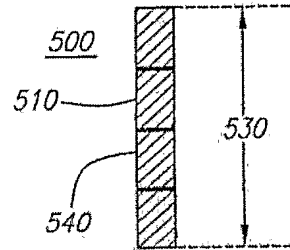

FIG. 6B

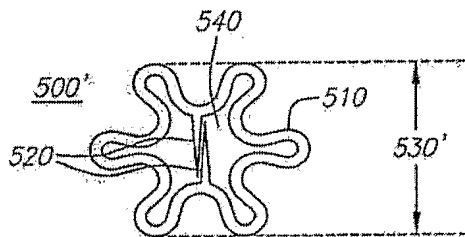

FIG. 6C

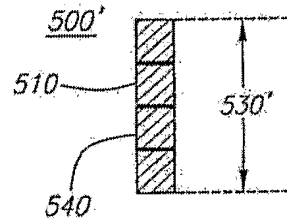

FIG. 6D

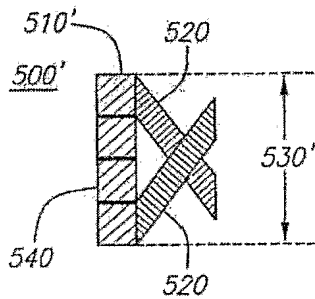

FIG. 6E

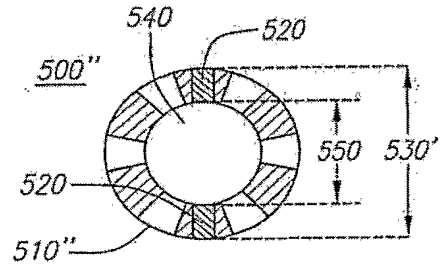
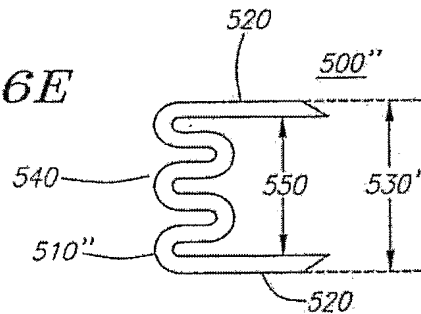

FIG. 6F



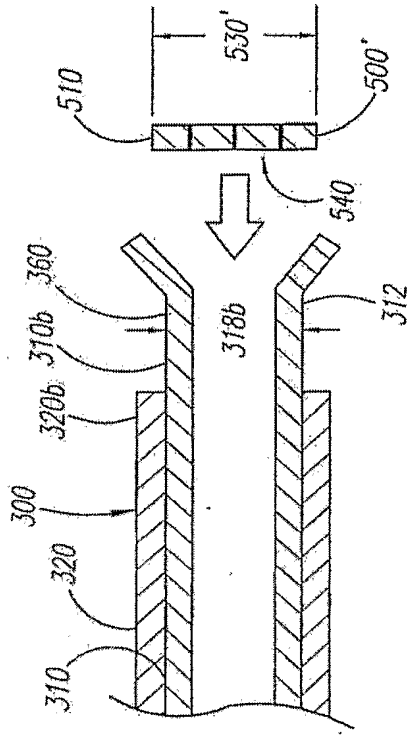

FIG. 7A

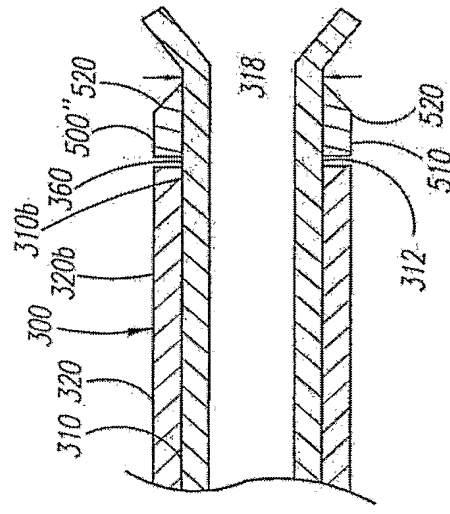

FIG. 7B

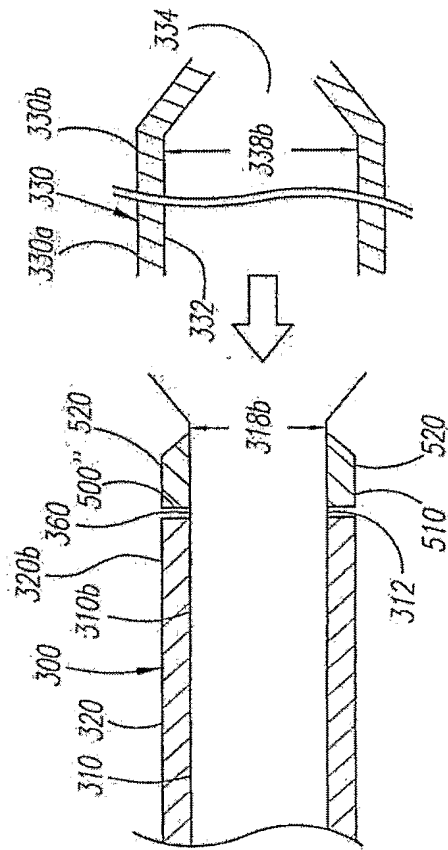

FIG. 7C

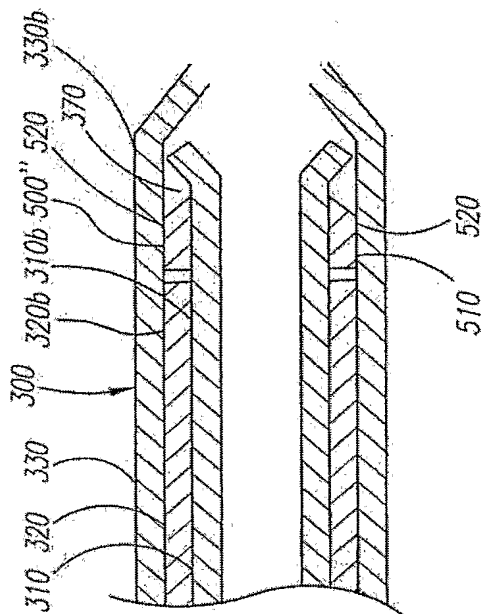

FIG. 7D

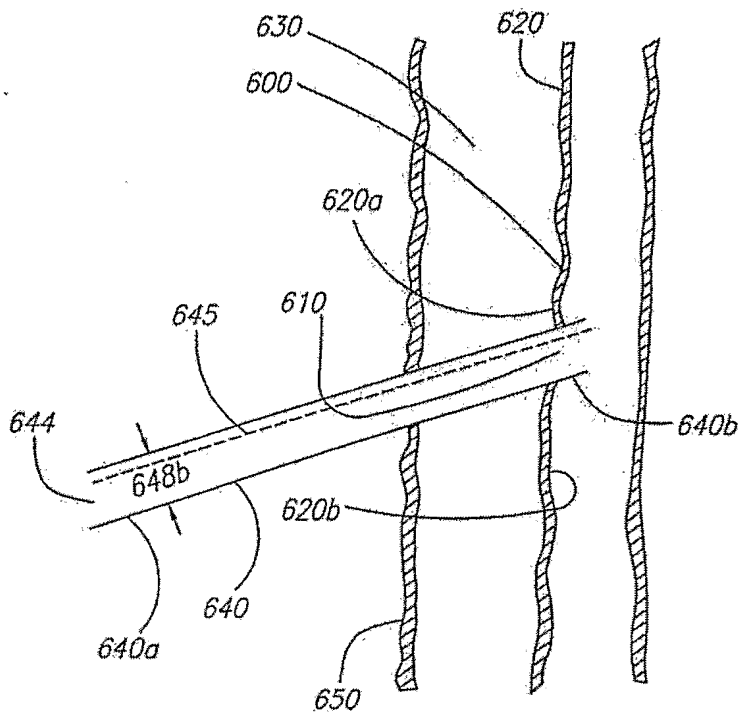

FIG. 8A

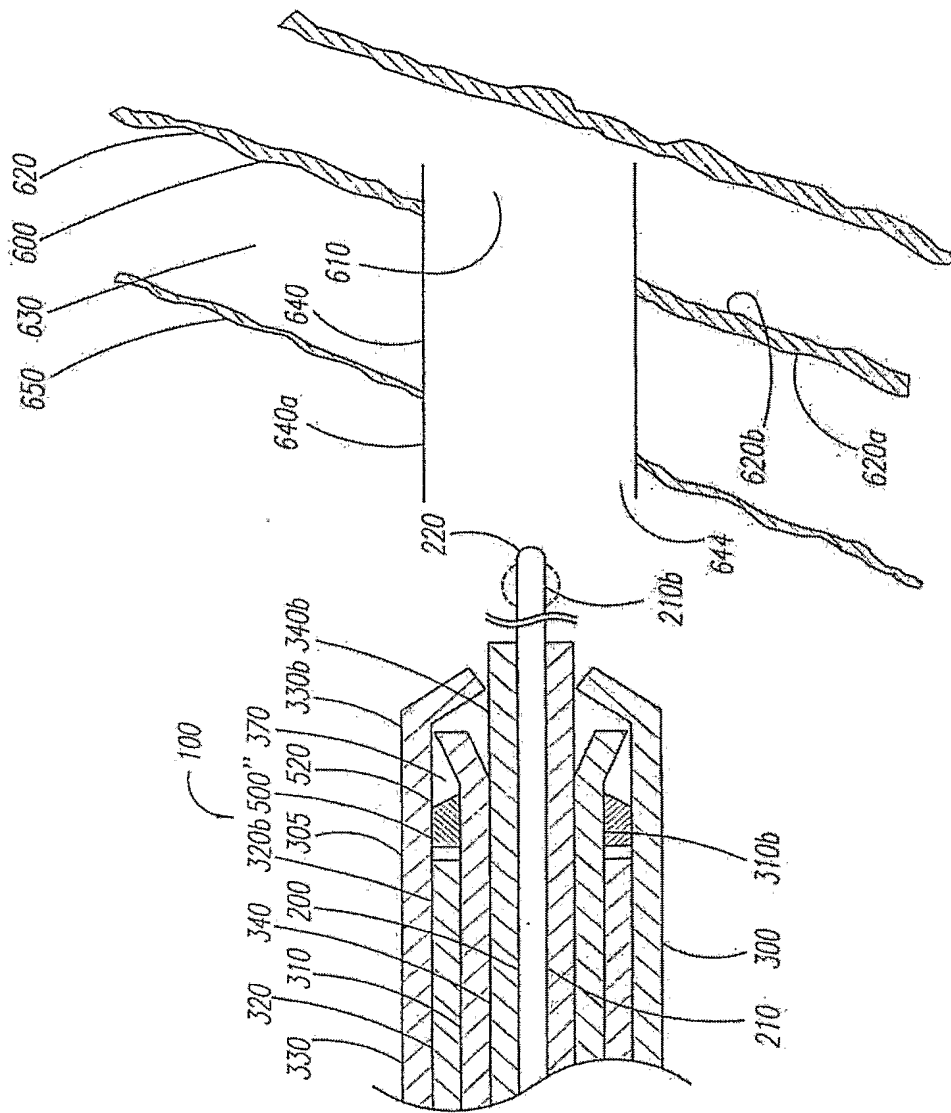

FIG. 8B

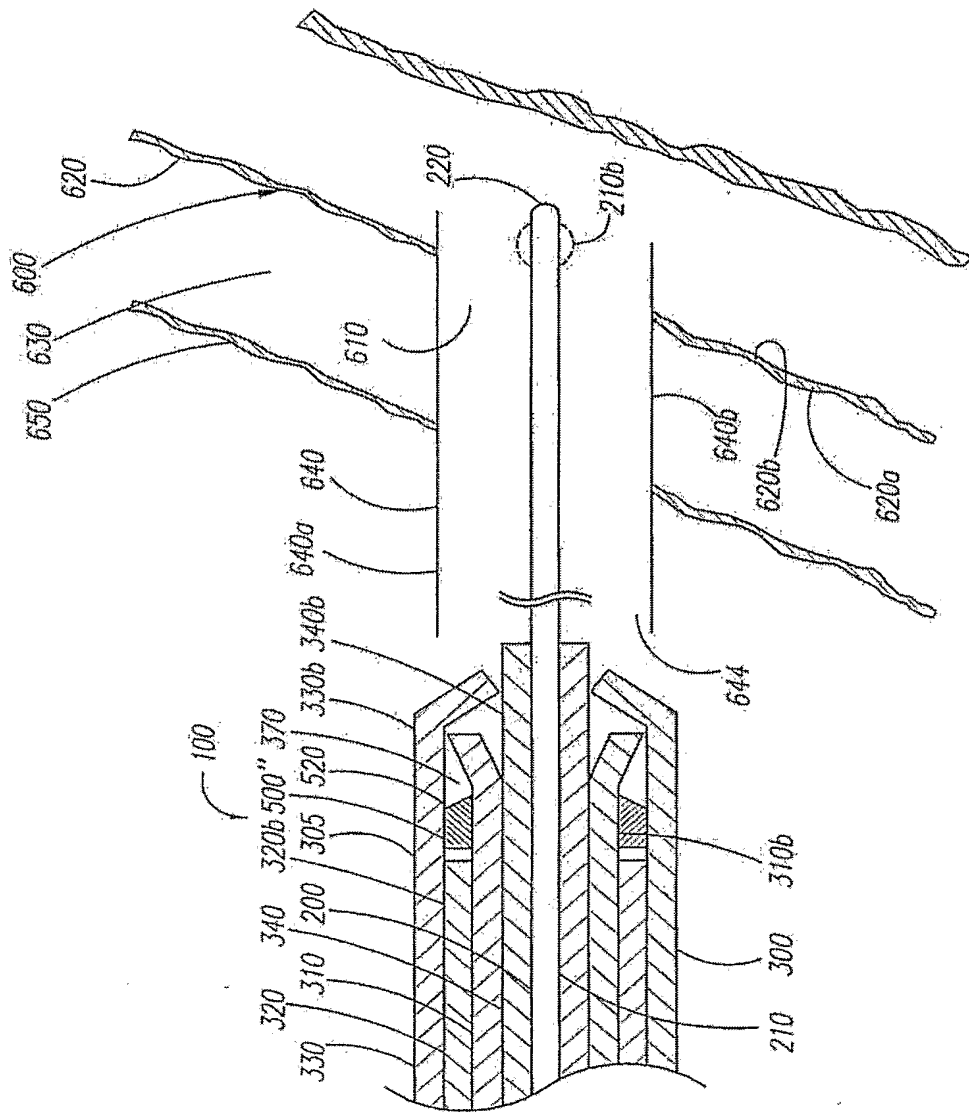

FIG. 8C

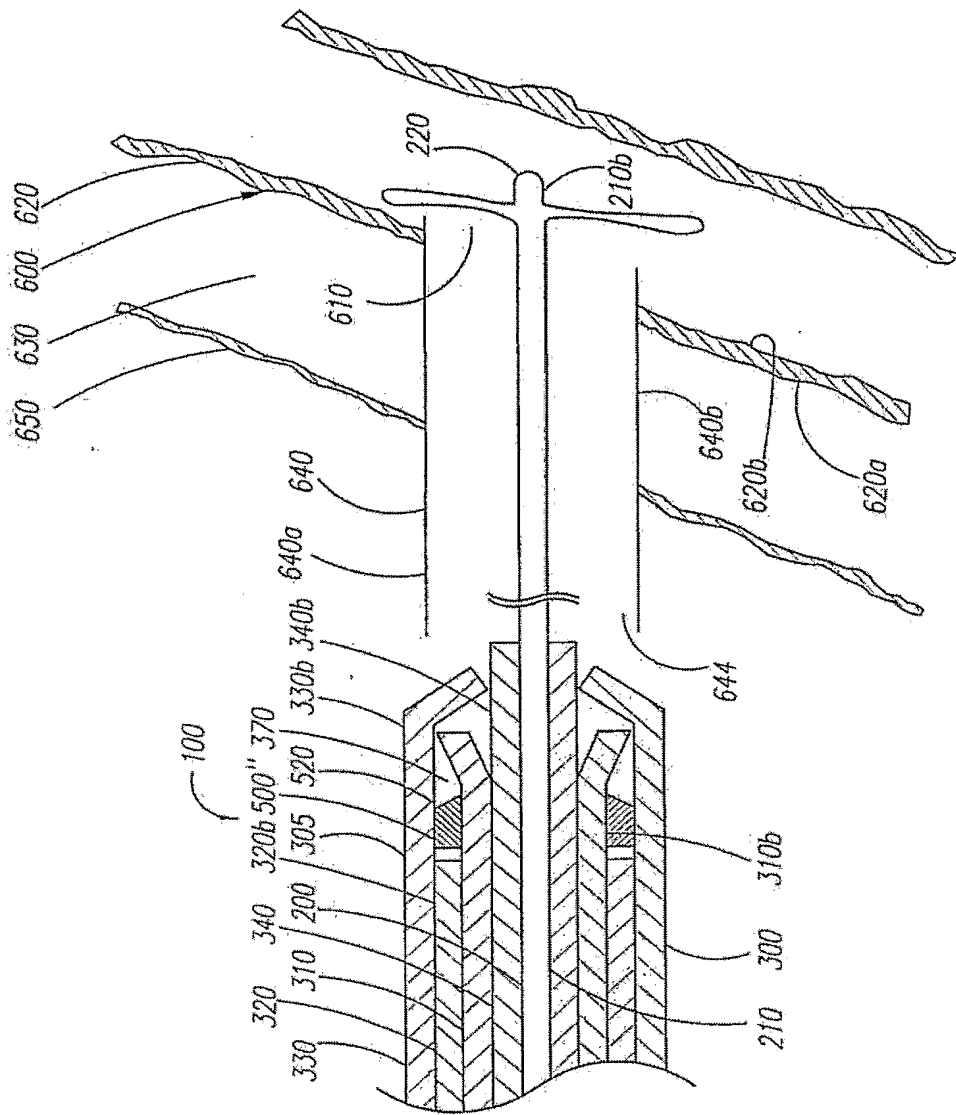

FIG. 8D

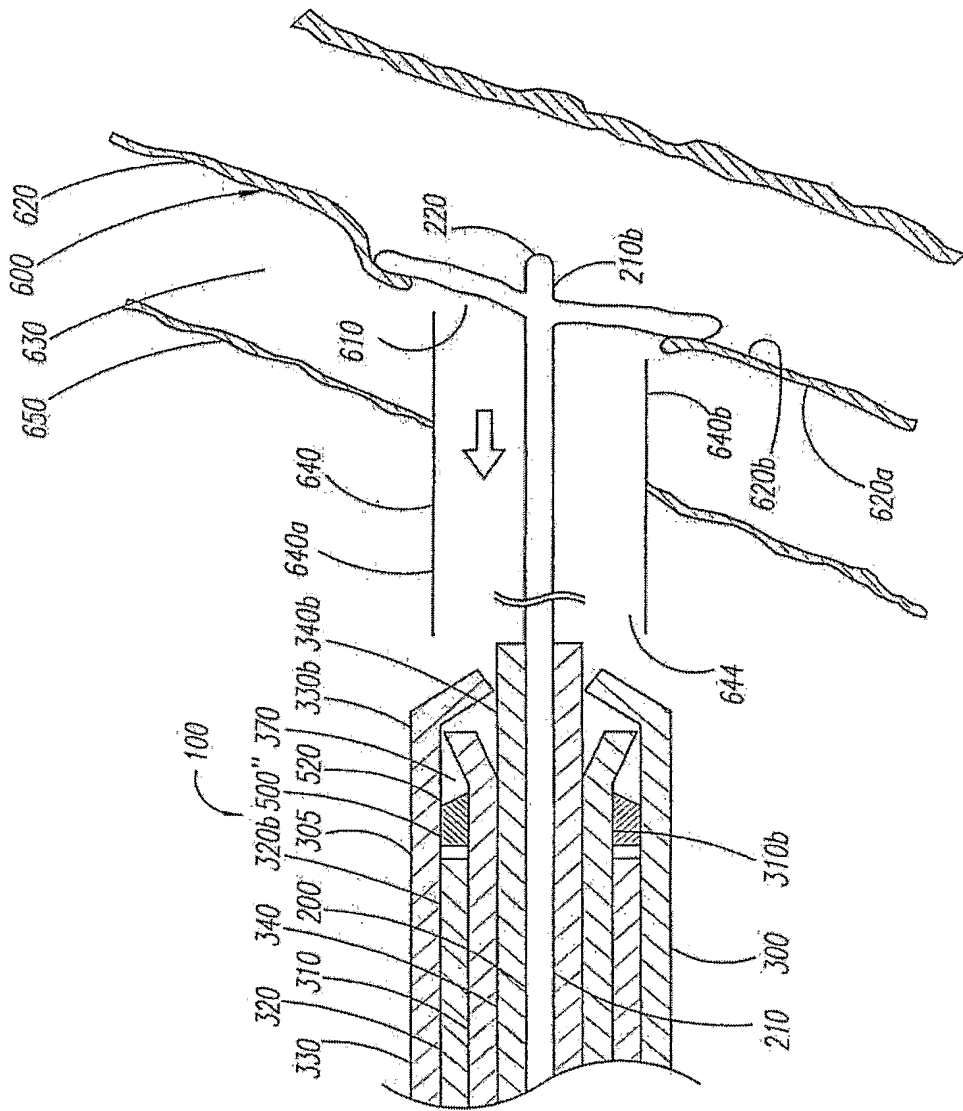

FIG. 8E

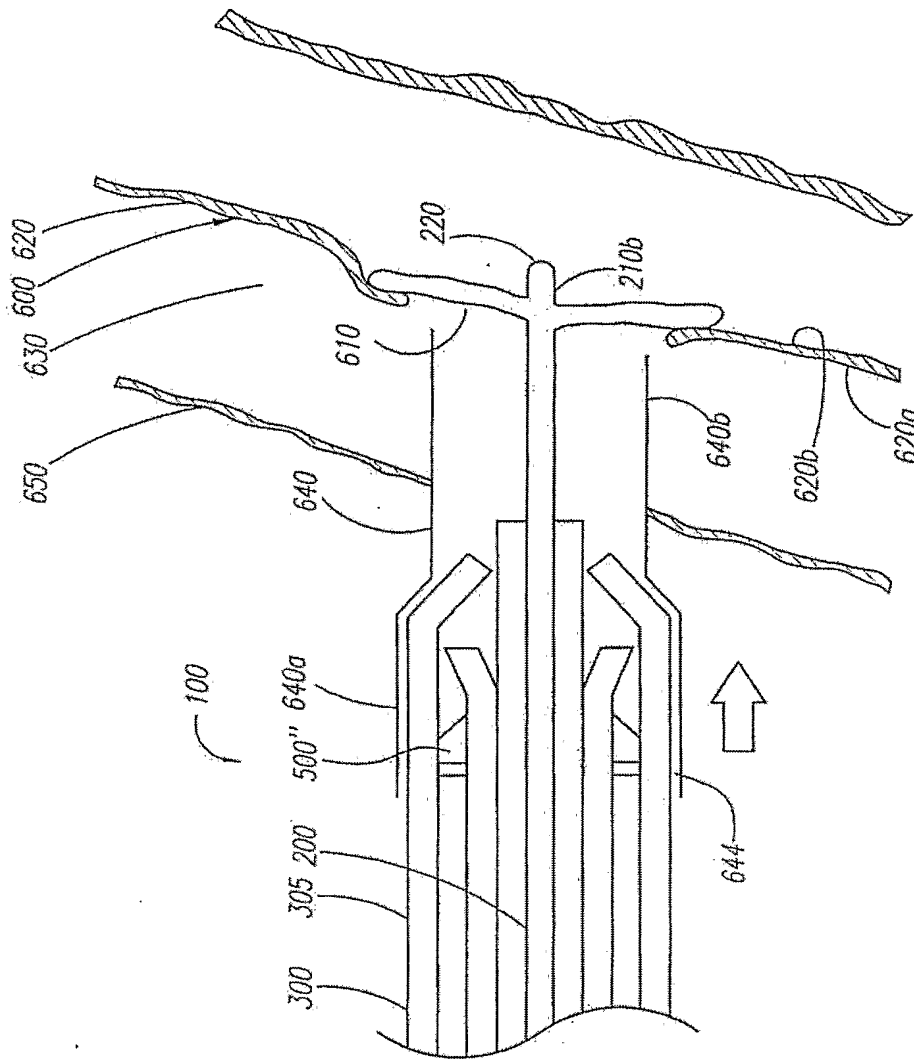

FIG. 8F

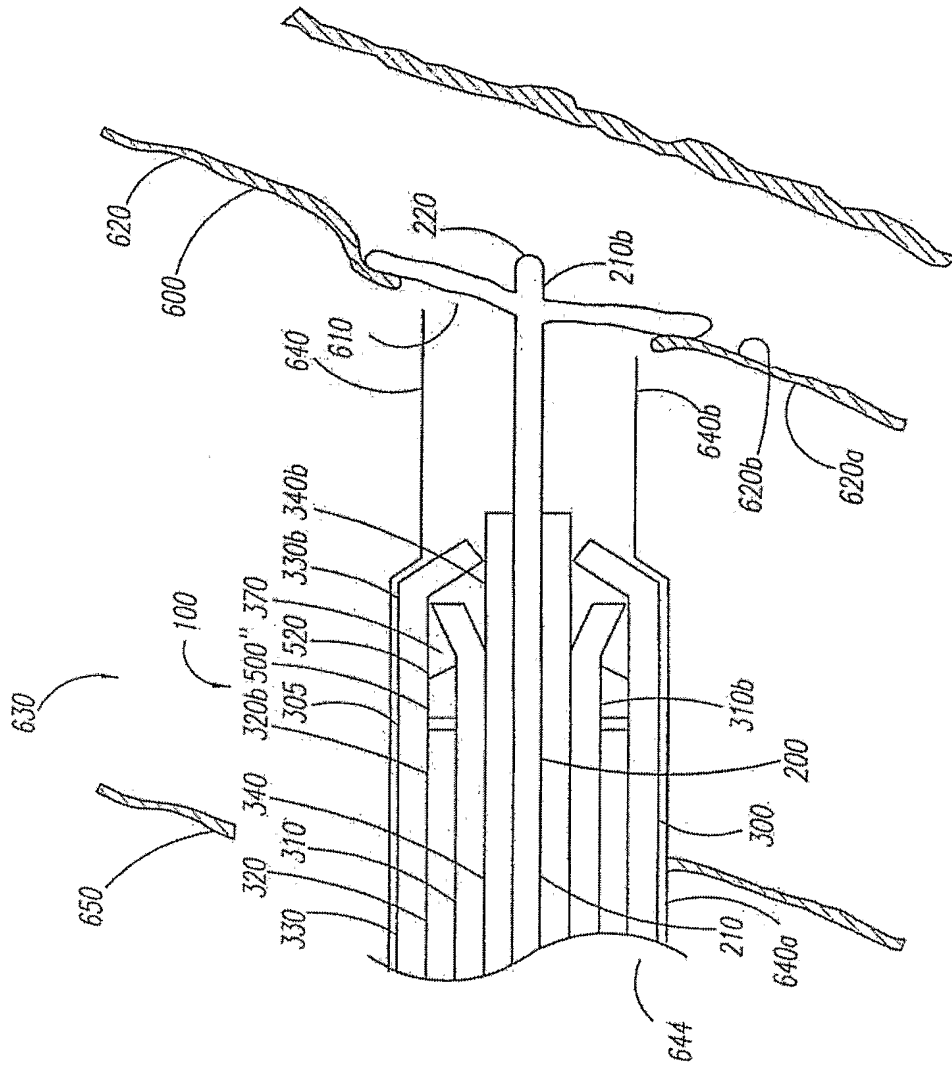

FIG. 8G

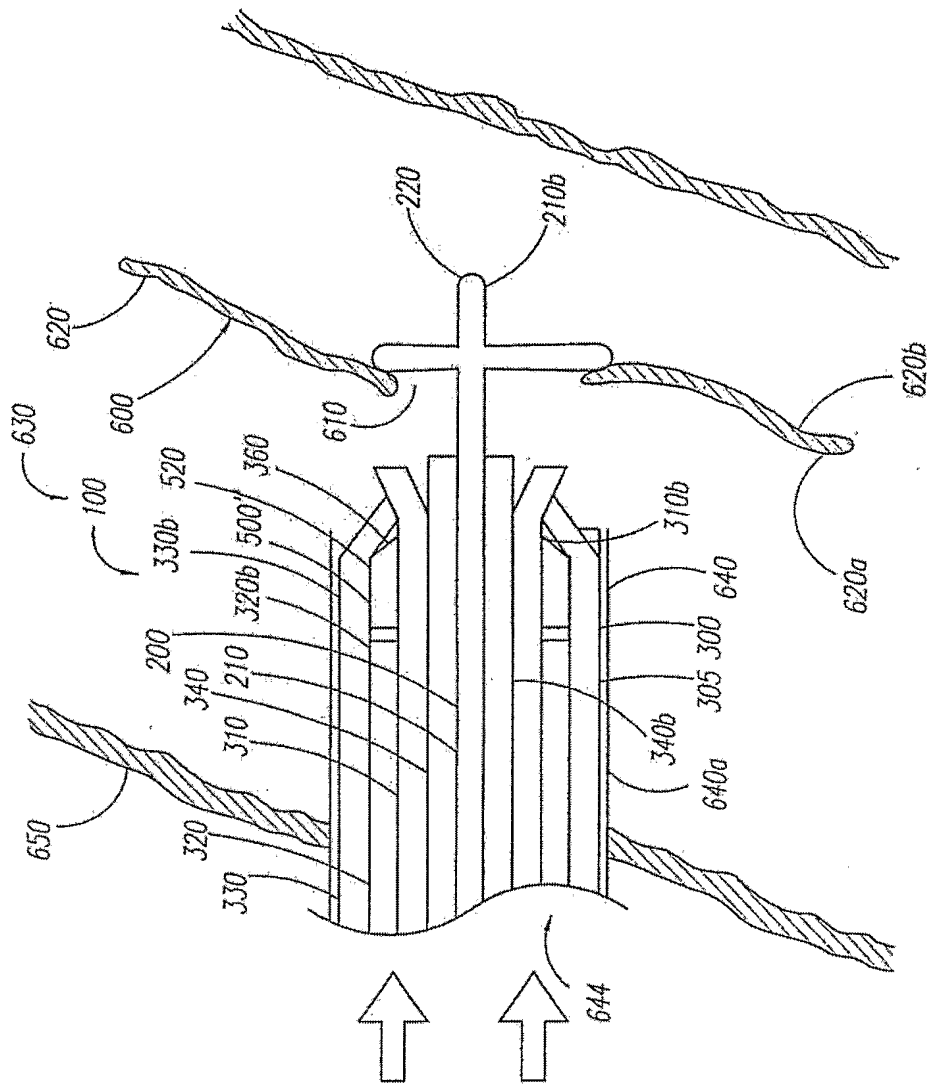

FIG. 8H

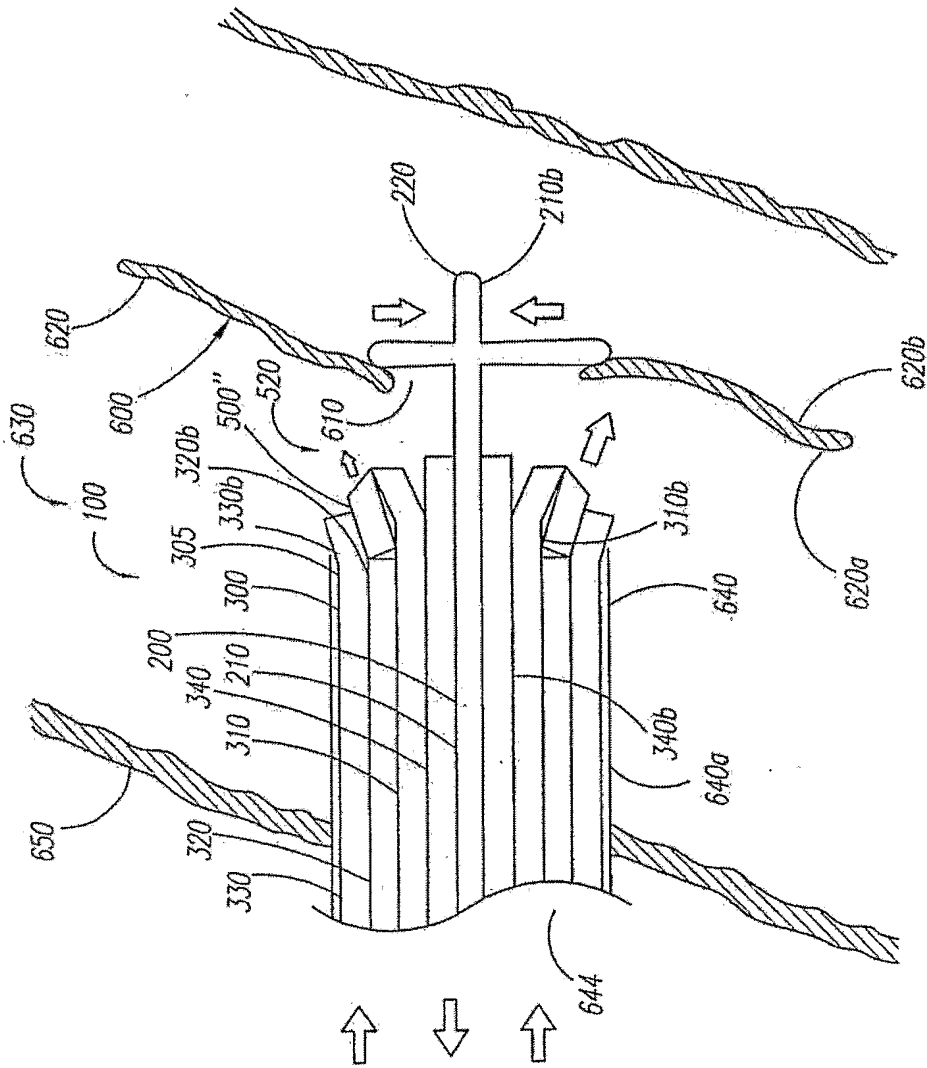

FIG. 8I

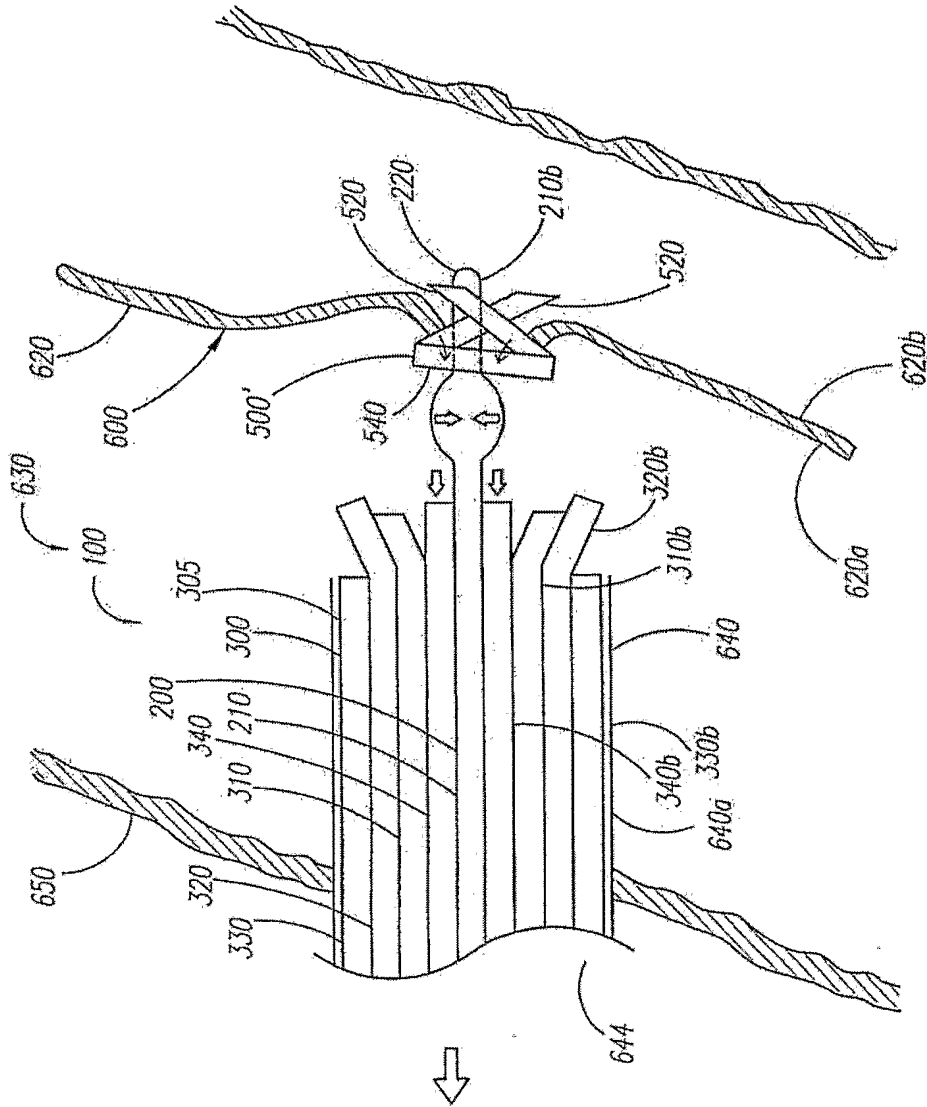

FIG. 8K

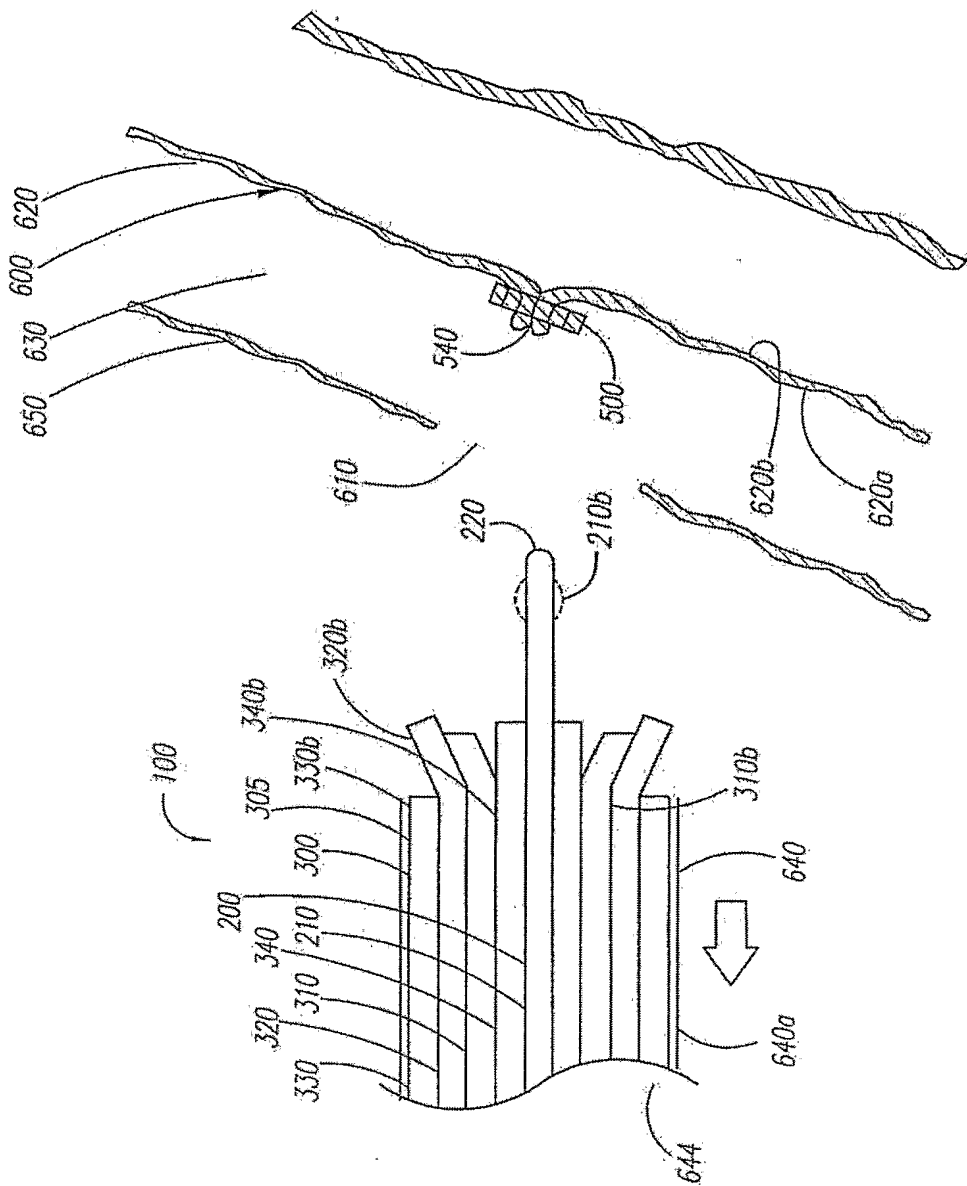

FIG. 8L

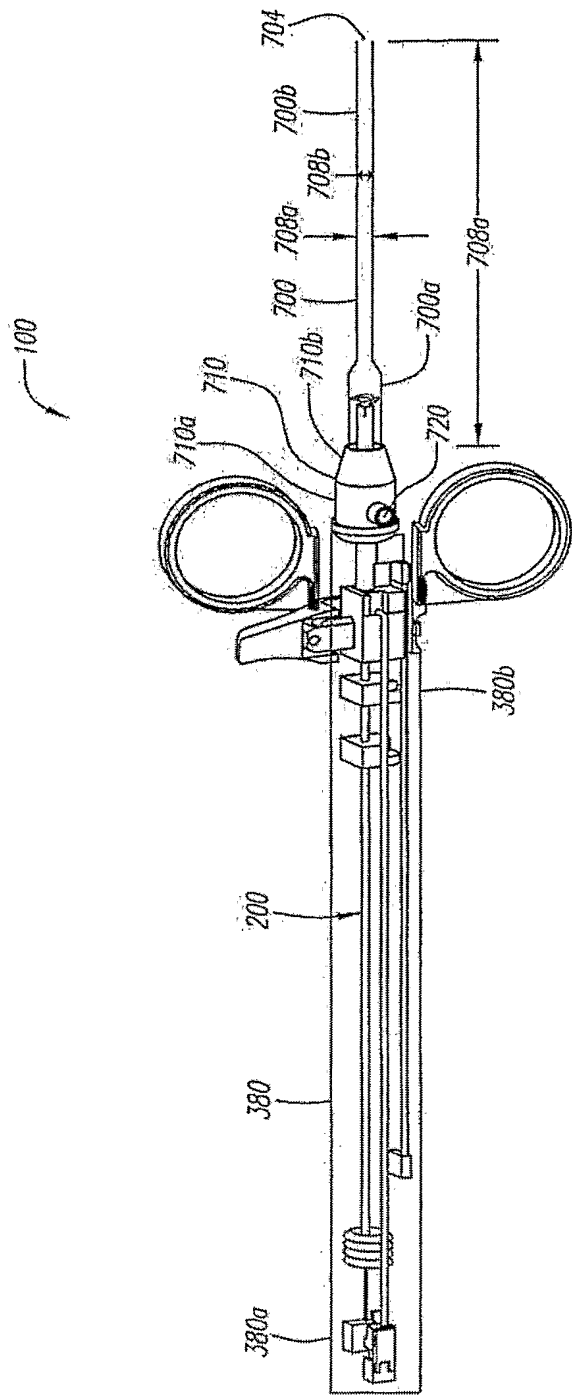

FIG. 9

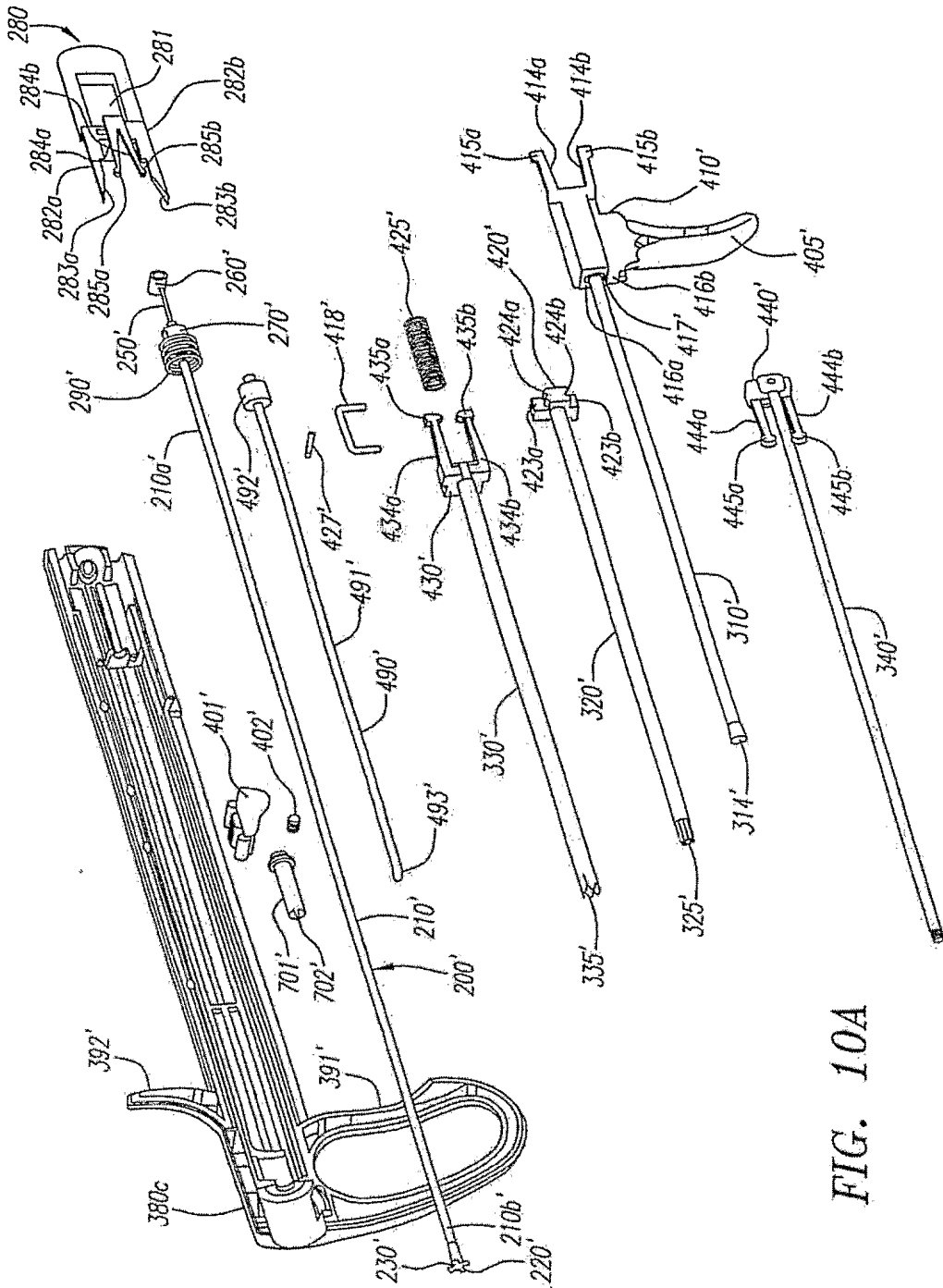

FIG. 10A

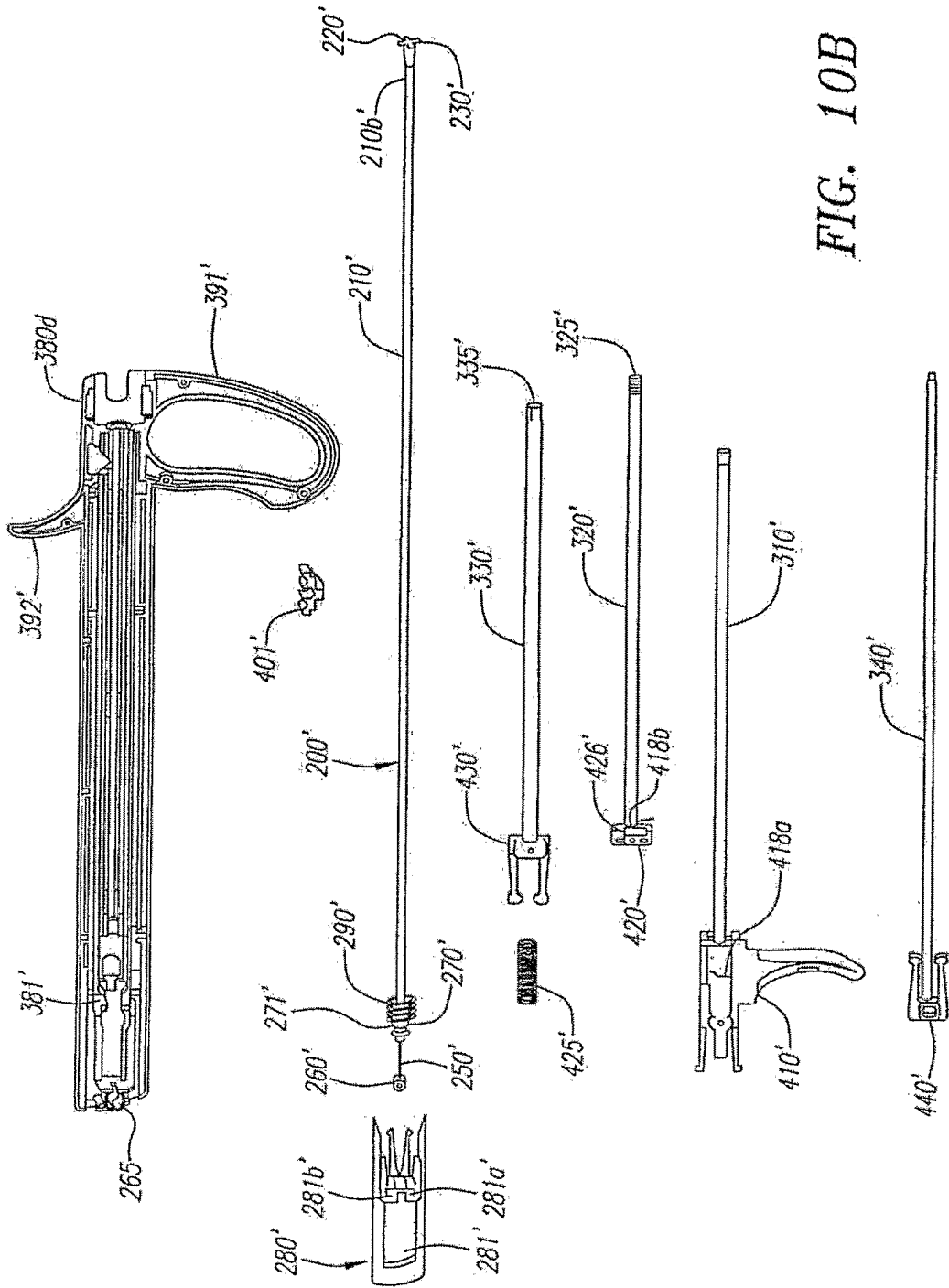

FIG. 10B

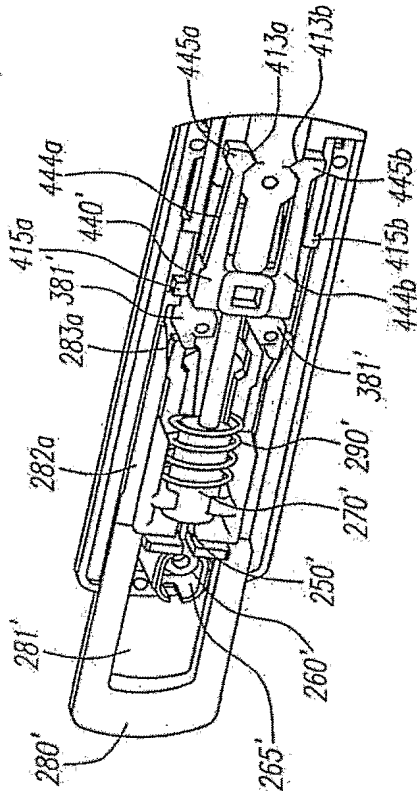

FIG. 11B

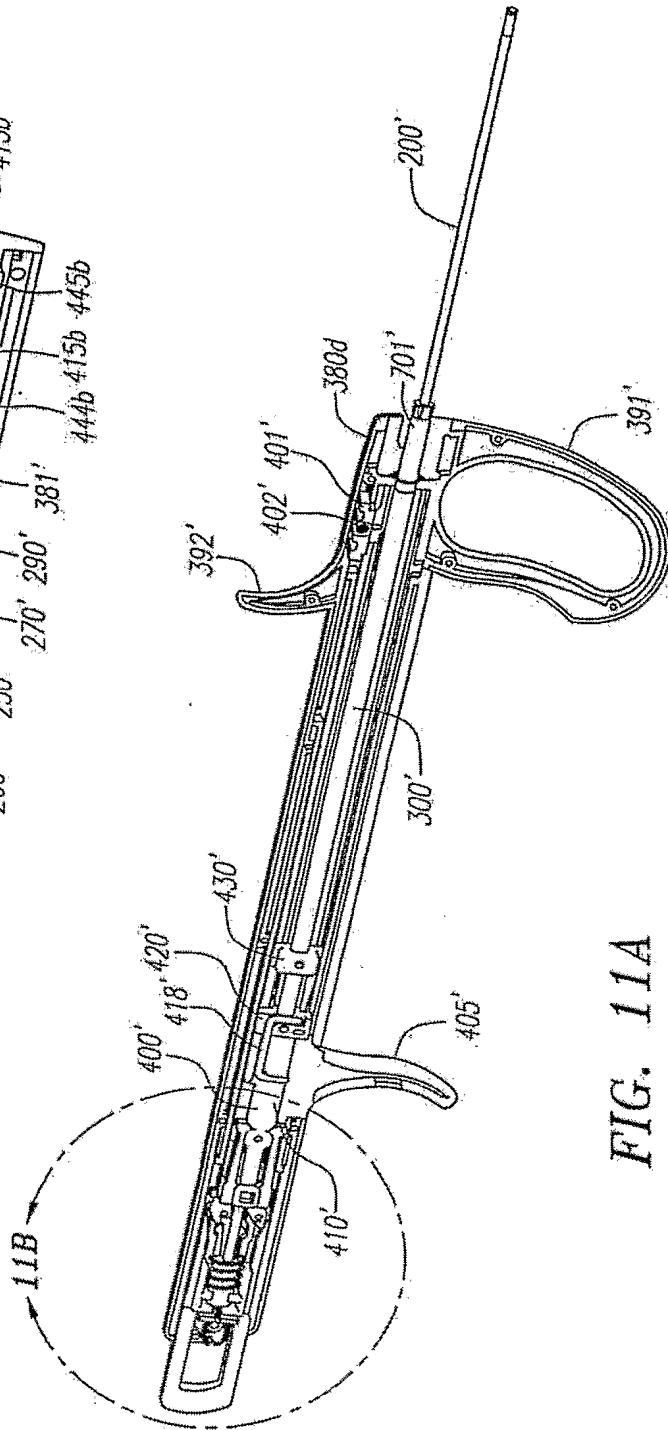

FIG. 11A

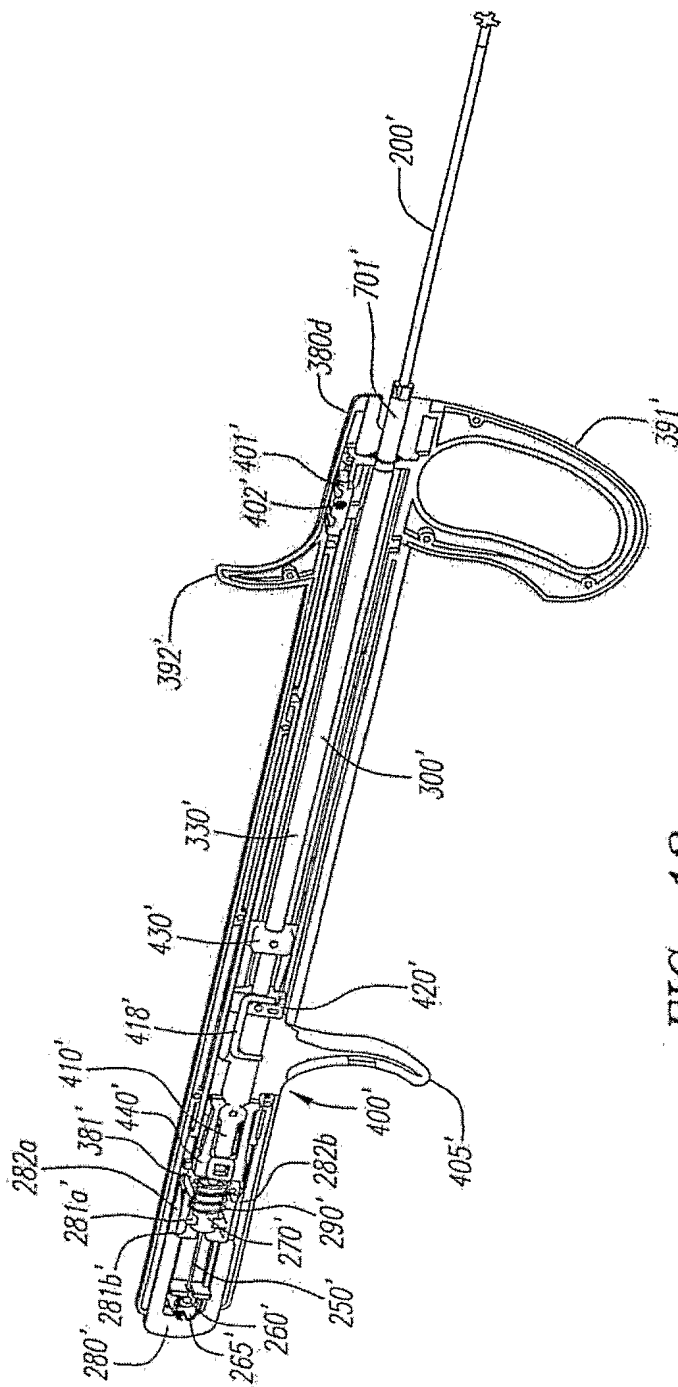
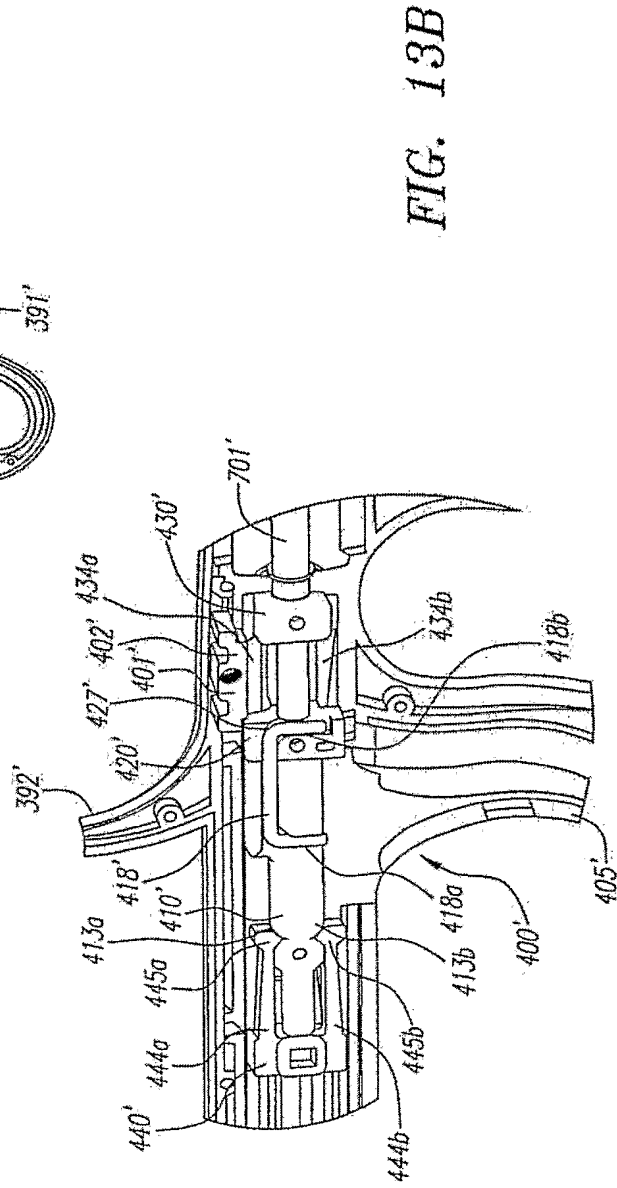
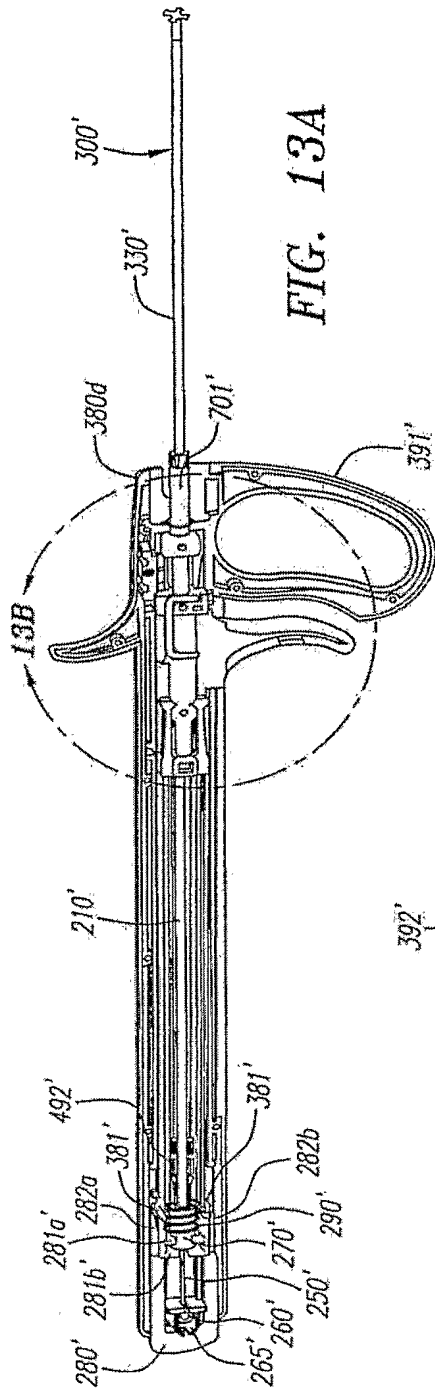

FIG. 12



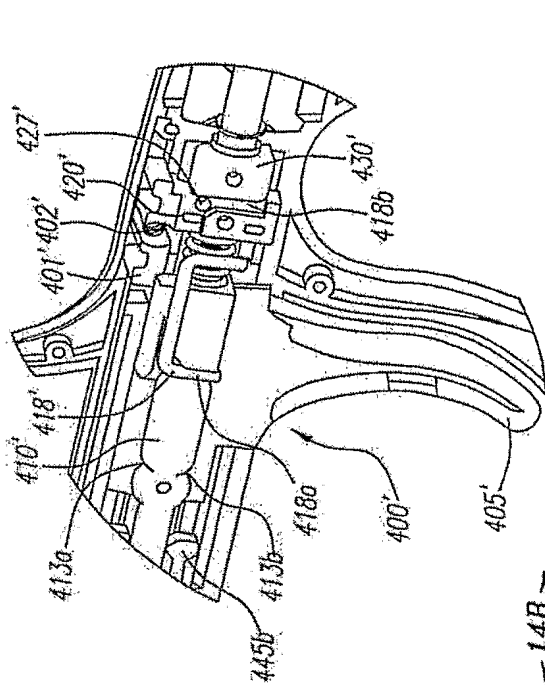

FIG. 14B

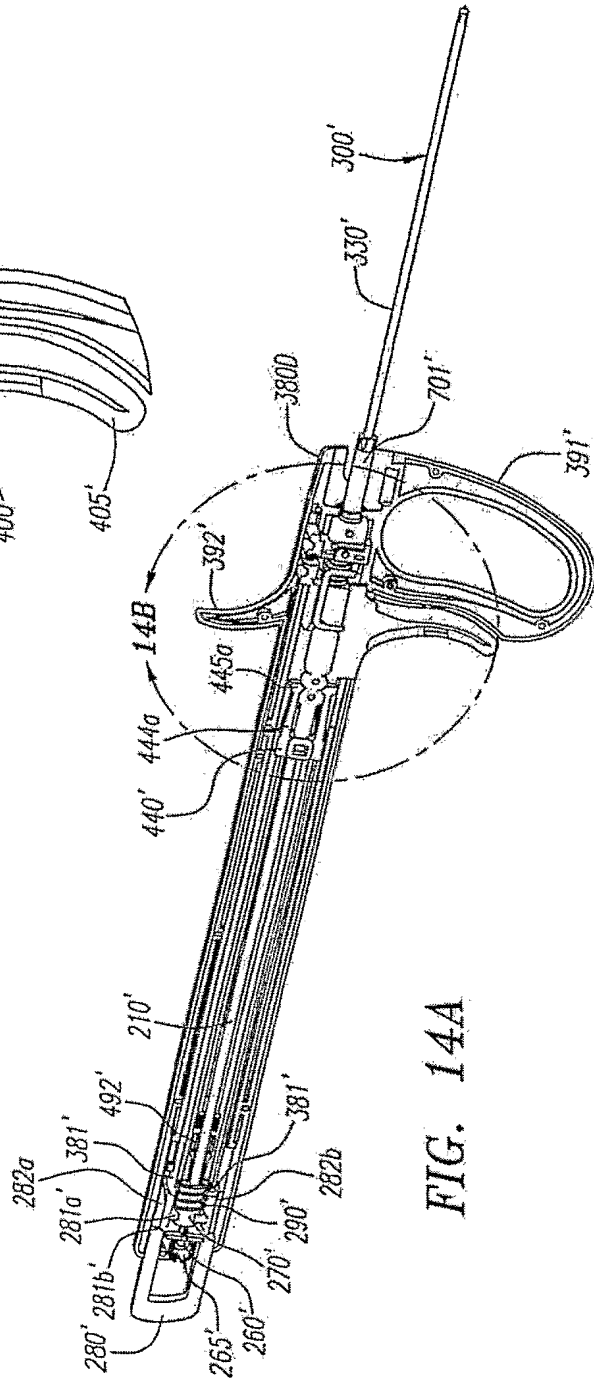

FIG. 14A

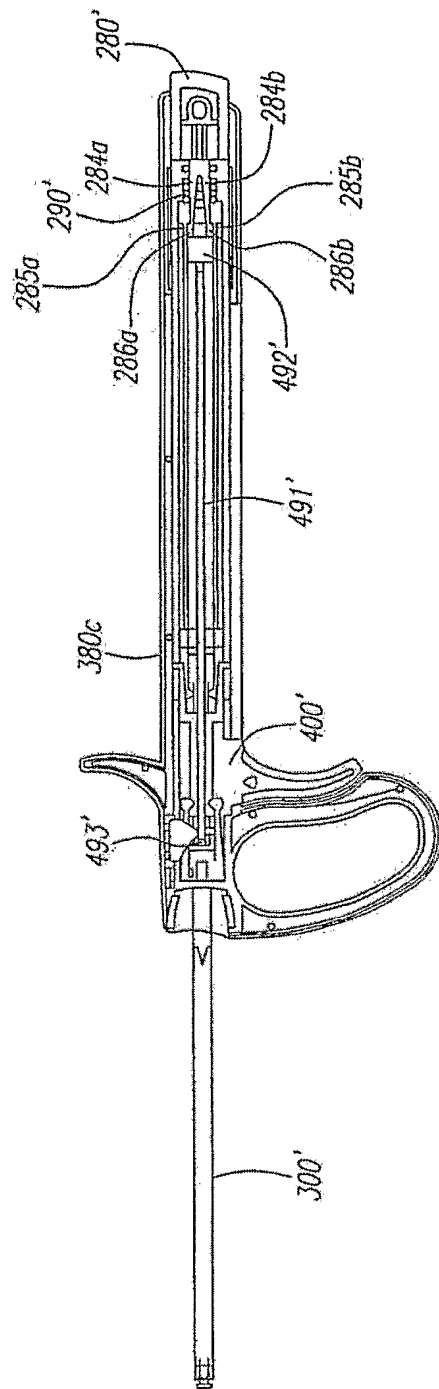
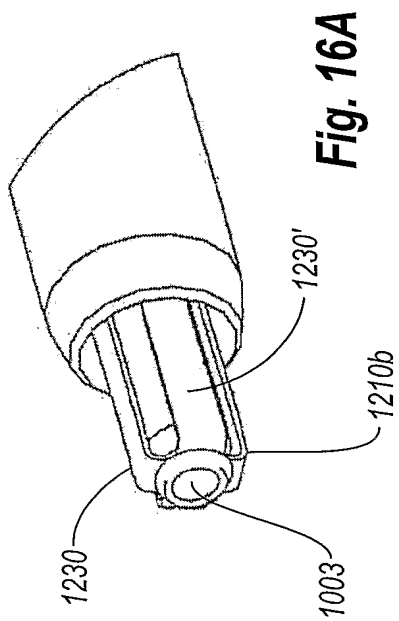
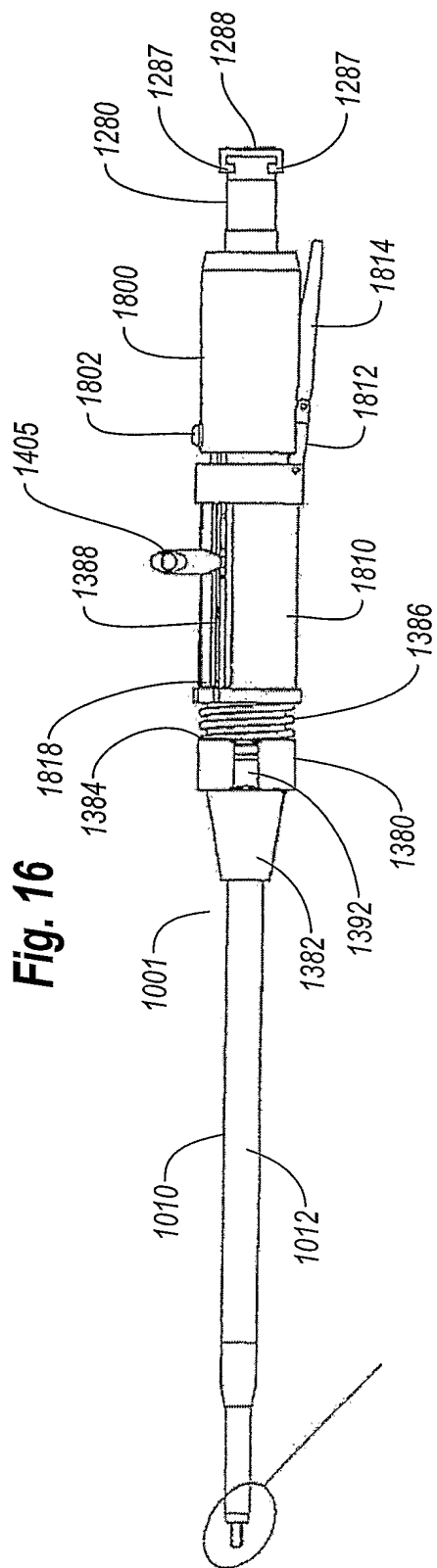

FIG. 15



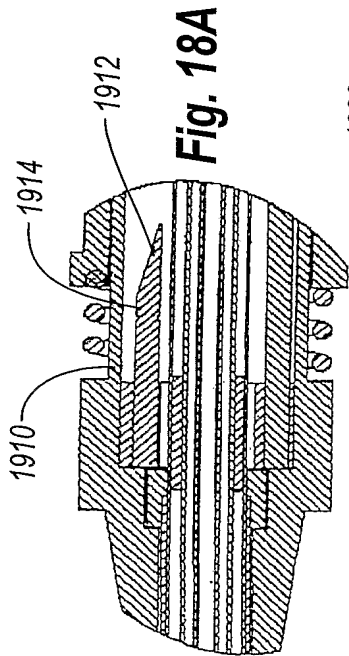

Fig. 18A

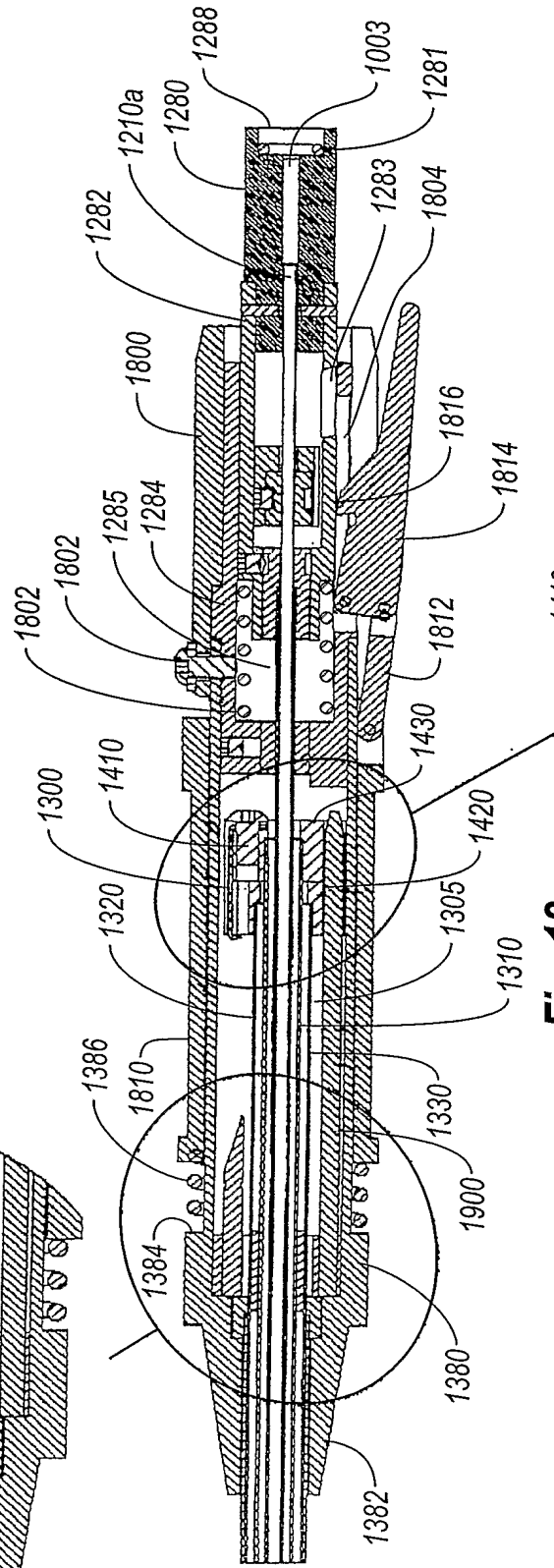

Fig. 18

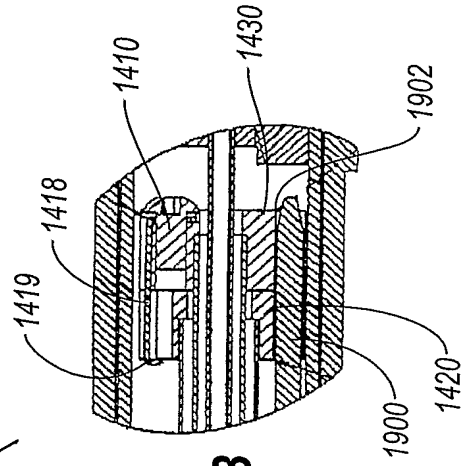

Fig. 18B

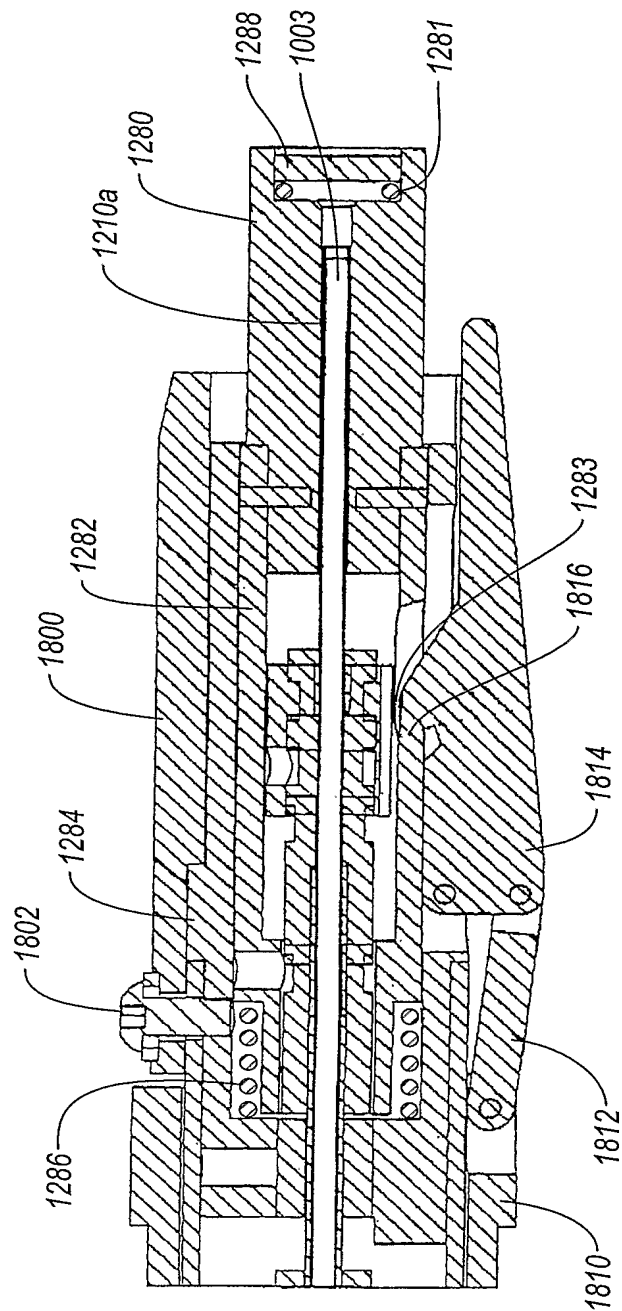

Fig. 19

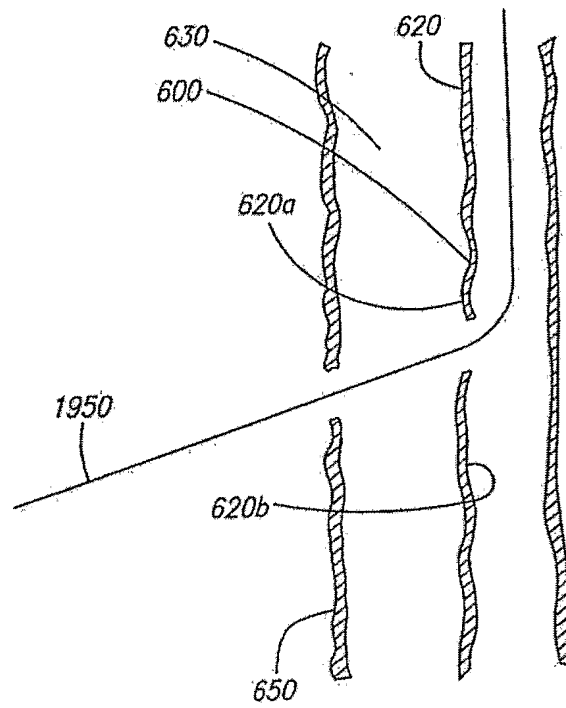

FIG. 20A

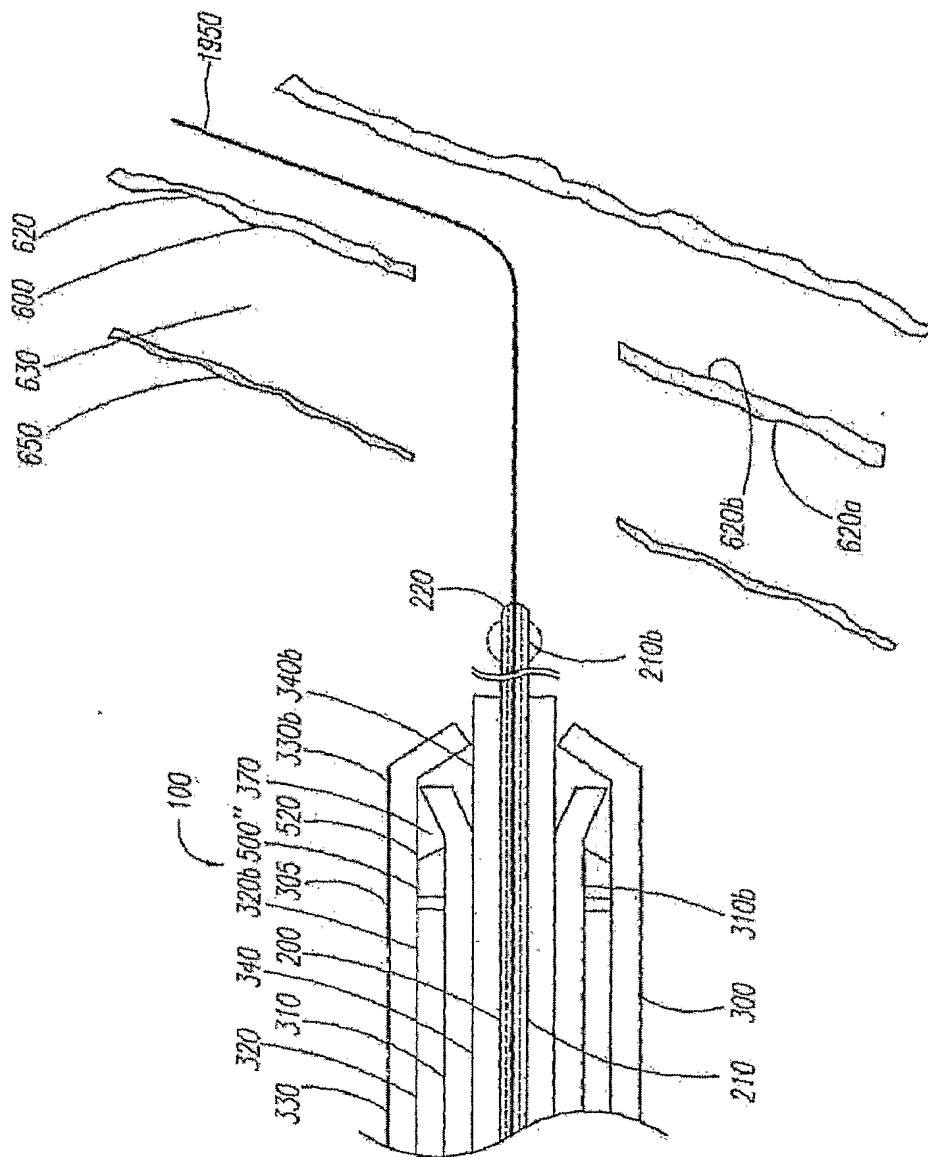

FIG. 20B

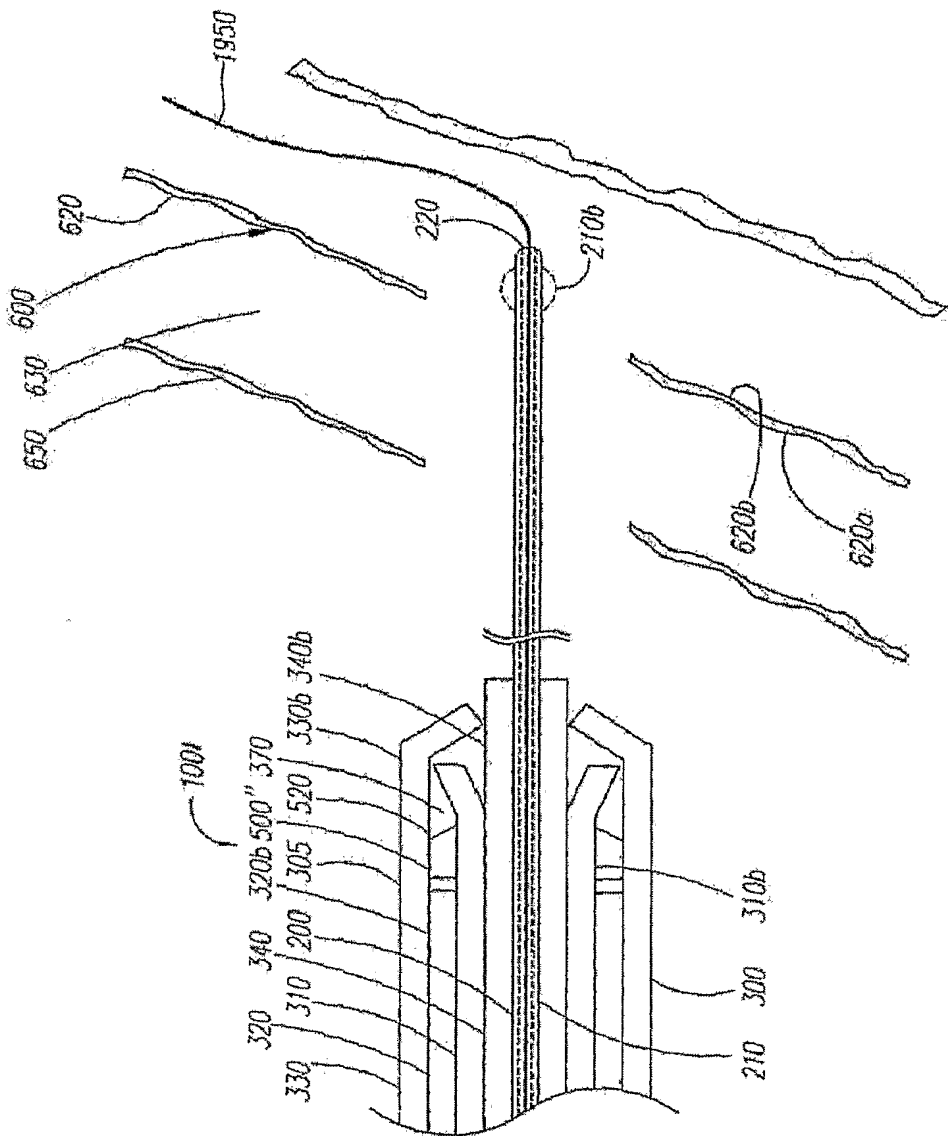

FIG. 20C

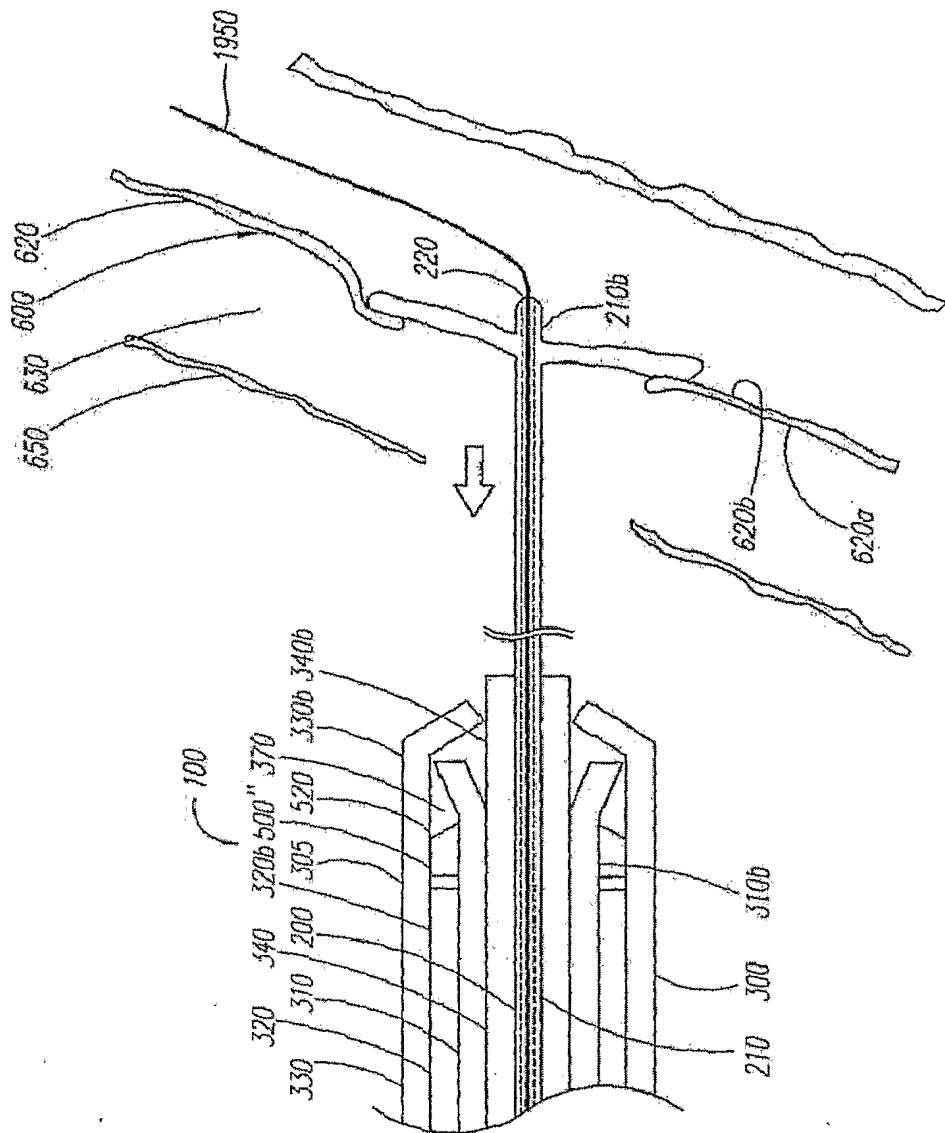

Fig. 20D

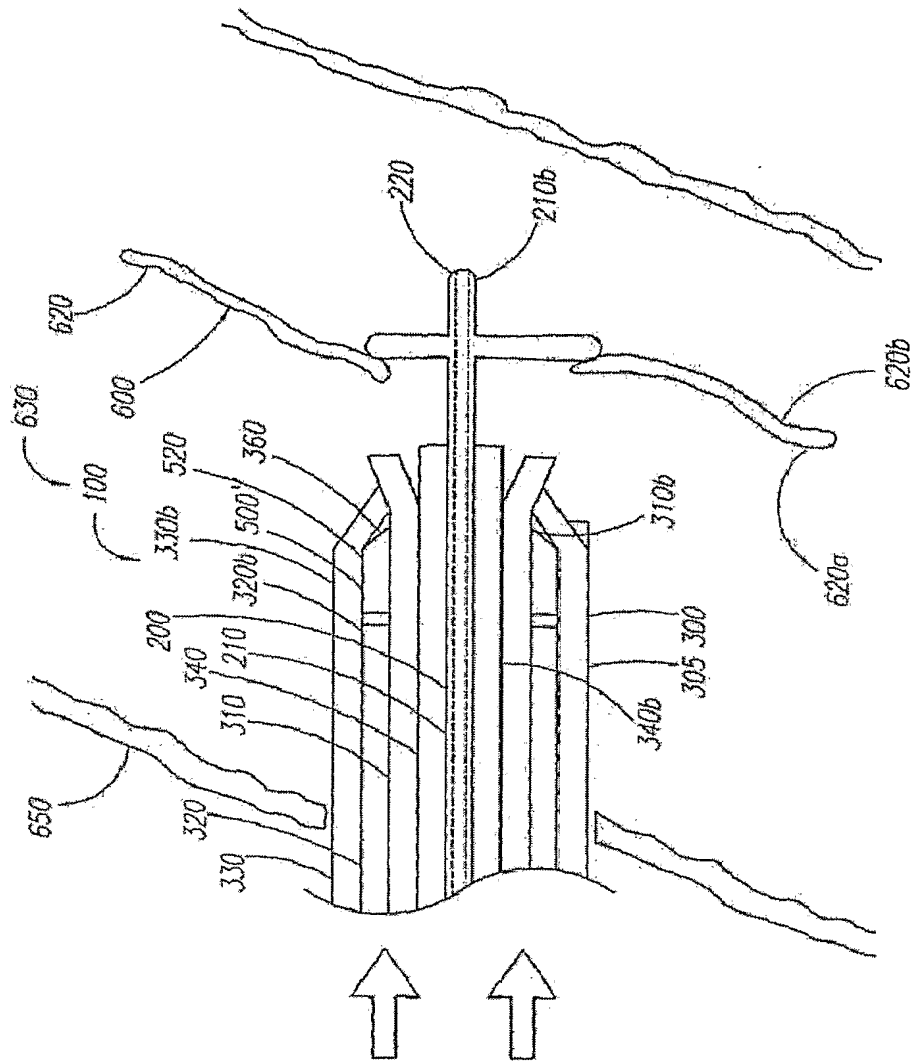

Fig. 20E

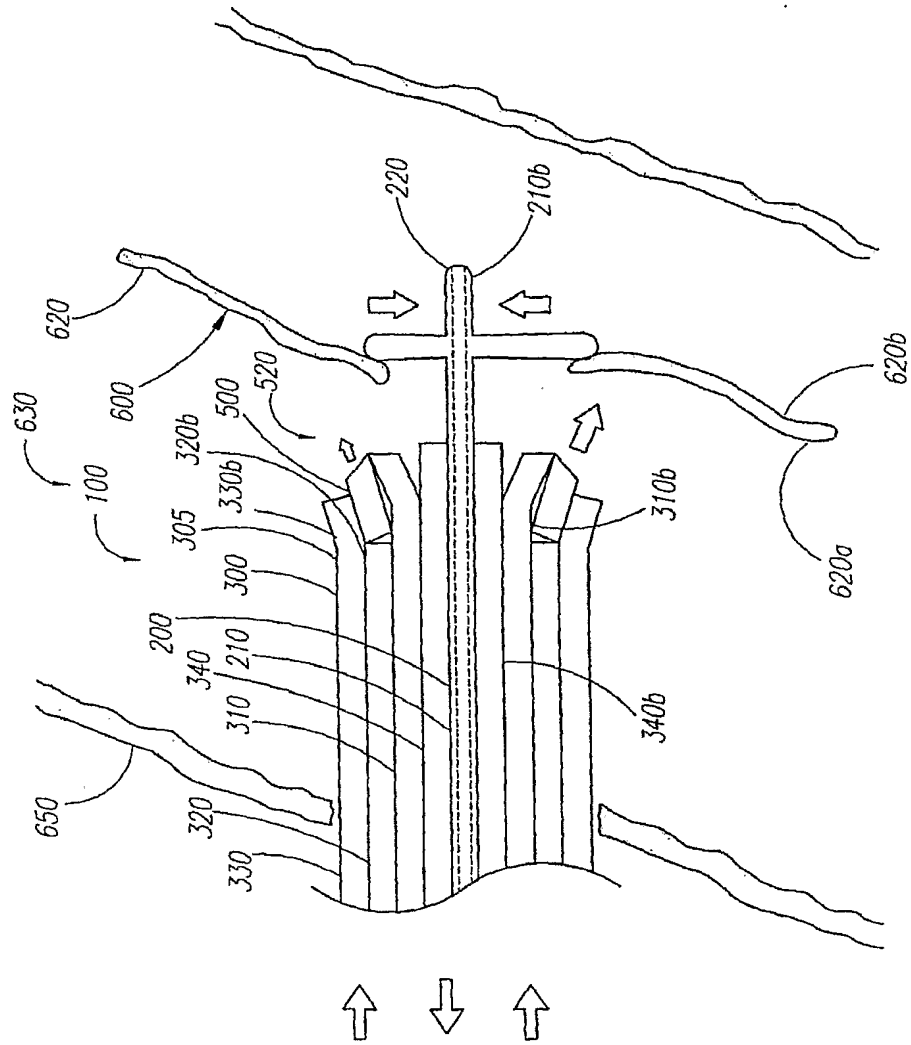

Fig. 20F

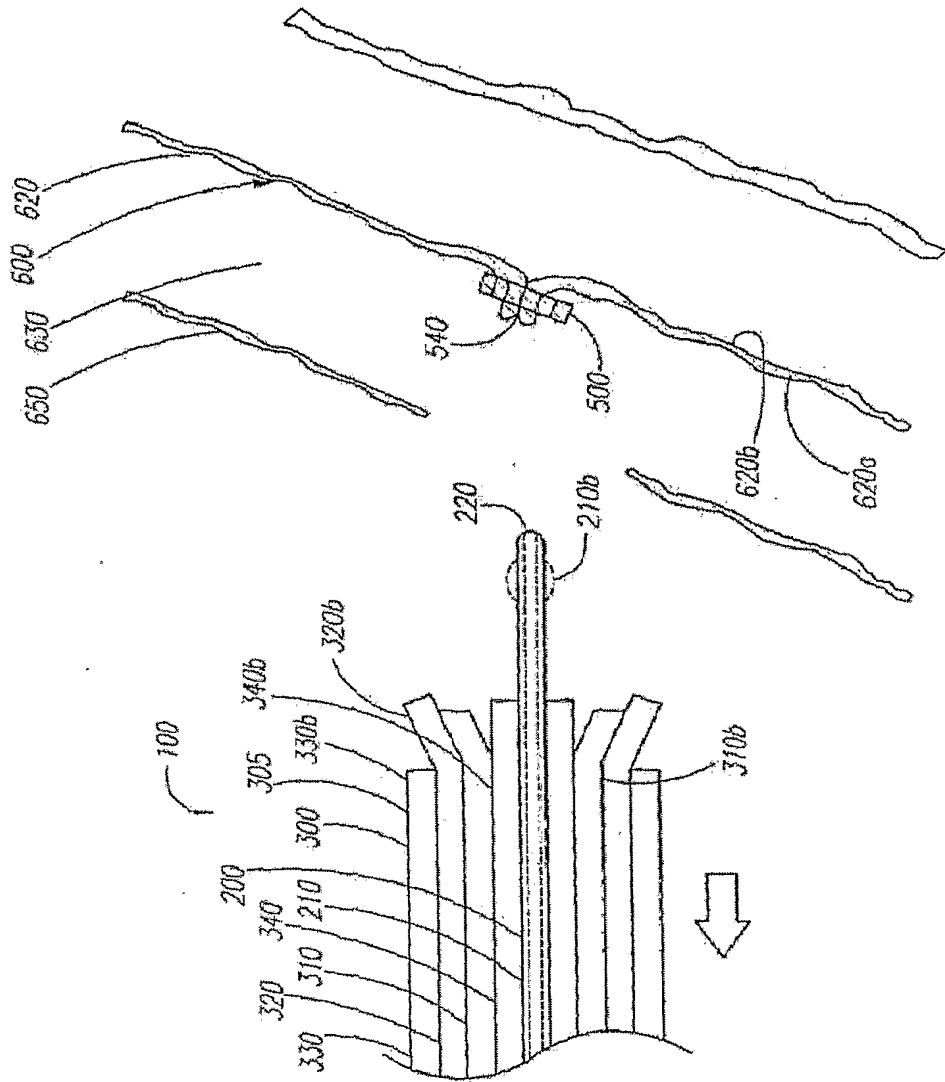

Fig. 20G

INTERNATIONAL SEARCH REPORT

International application No
PCT/US2006/003432

A. CLASSIFICATION OF SUBJECT MATTER
INV. A61B17/00 A61B17/08

According to International Patent Classification (IPC) or to both national classification and IPC

B. FIELDS SEARCHED

Minimum documentation searched (classification system followed by classification symbols)
A61B

Documentation searched other than minimum documentation to the extent that such documents are included in the fields searched

Electronic data base consulted during the international search (name of data base and, where practical, search terms used)

EPO-Internal

C. DOCUMENTS CONSIDERED TO BE RELEVANT

Category*	Citation of document, with indication, where appropriate, of the relevant passages	Relevant to claim No.
X	US 2004/153123 A1 (PALERMO THOMAS J ET AL) 5 August 2004 (2004-08-05) the whole document	1-21
X	US 6 623 510 B2 (CARLEY MICHAEL T ET AL) 23 September 2003 (2003-09-23) cited in the application column 12, line 12 - column 13, line 17; figures 6,9,10a-10d	1-8,14, 15,20,21
X	WO 03/071956 A (INTEGRATED VASCULAR SYSTEMS, INC) 4 September 2003 (2003-09-04) figures 6a-7b,12a-12i	1-8,14, 15
A	US 2002/026208 A1 (ROE STEVEN N ET AL) 28 February 2002 (2002-02-28) figures 1-6	1-5

Further documents are listed in the continuation of Box C.

See patent family annex.

* Special categories of cited documents :

- "A" document defining the general state of the art which is not considered to be of particular relevance
- "E" earlier document but published on or after the international filing date
- "L" document which may throw doubts on priority claim(s) or which is cited to establish the publication date of another citation or other special reason (as specified)
- "O" document referring to an oral disclosure, use, exhibition or other means
- "P" document published prior to the international filing date but later than the priority date claimed

- "T" later document published after the international filing date or priority date and not in conflict with the application but cited to understand the principle or theory underlying the invention
- "X" document of particular relevance; the claimed invention cannot be considered novel or cannot be considered to involve an inventive step when the document is taken alone
- "Y" document of particular relevance; the claimed invention cannot be considered to involve an inventive step when the document is combined with one or more other such documents, such combination being obvious to a person skilled in the art.
- "&" document member of the same patent family

Date of the actual completion of the international search

8 June 2006

Date of mailing of the international search report

21/06/2006

Name and mailing address of the ISA/
European Patent Office, P.B. 5818 Patentlaan 2
NL - 2280 HV Rijswijk
Tel. (+31-70) 340-2040, Tx. 31 651 epo nl,
Fax: (+31-70) 340-3016

Authorized officer

Béraud, F

INTERNATIONAL SEARCH REPORT

International application No
PCT/US2006/003432

C(Continuation). DOCUMENTS CONSIDERED TO BE RELEVANT

Category*	Citation of document, with indication, where appropriate, of the relevant passages	Relevant to claim No.
A	WO 03/101310 A (CUMMINS, CHRISTY; STEVENSON, ROBERT) 11 December 2003 (2003-12-11) figures 11-15 -----	1

INTERNATIONAL SEARCH REPORT

International application No.
PCT/US2006/003432

Box II Observations where certain claims were found unsearchable (Continuation of item 2 of first sheet)

This International Search Report has not been established in respect of certain claims under Article 17(2)(a) for the following reasons:

1. Claims Nos.: 22-41
because they relate to subject matter not required to be searched by this Authority, namely:
Rule 39.1(iv) PCT - Method for treatment of the human or animal body by surgery
2. Claims Nos.:
because they relate to parts of the International Application that do not comply with the prescribed requirements to such an extent that no meaningful International Search can be carried out, specifically:
3. Claims Nos.:
because they are dependent claims and are not drafted in accordance with the second and third sentences of Rule 6.4(a).

Box III Observations where unity of invention is lacking (Continuation of item 3 of first sheet)

This International Searching Authority found multiple inventions in this international application, as follows:

1. As all required additional search fees were timely paid by the applicant, this International Search Report covers all searchable claims.
2. As all searchable claims could be searched without effort justifying an additional fee, this Authority did not invite payment of any additional fee.
3. As only some of the required additional search fees were timely paid by the applicant, this International Search Report covers only those claims for which fees were paid, specifically claims Nos.:
4. No required additional search fees were timely paid by the applicant. Consequently, this International Search Report is restricted to the invention first mentioned in the claims; it is covered by claims Nos.:

Remark on Protest

- The additional search fees were accompanied by the applicant's protest.
- No protest accompanied the payment of additional search fees.

INTERNATIONAL SEARCH REPORT

Information on patent family members

International application No

PCT/US2006/003432

Patent document cited in search report	Publication date	Patent family member(s)	Publication date
US 2004153123 A1	05-08-2004	US 2004153122 A1	05-08-2004
US 6623510 B2	23-09-2003	AU 2018602 A	18-06-2002
		CA 2431573 A1	13-06-2002
		EP 1339327 A2	03-09-2003
		JP 2004514529 T	20-05-2004
		WO 0245593 A2	13-06-2002
		US 2002188318 A1	12-12-2002
		US 2002082641 A1	27-06-2002
WO 03071956 A	04-09-2003	AU 2003213147 A1	09-09-2003
		EP 1478280 A2	24-11-2004
US 2002026208 A1	28-02-2002	NONE	
WO 03101310 A	11-12-2003	AU 2003238642 A1	19-12-2003
		CA 2488688 A1	11-12-2003
		EP 1513453 A1	16-03-2005
		JP 2005528161 T	22-09-2005